

SECTION A-A
SCALE 1-1

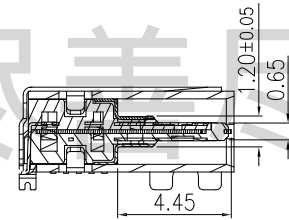

SECTION B-B
SCALE 1-1

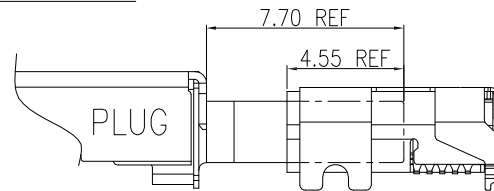

MATING INTERFACE

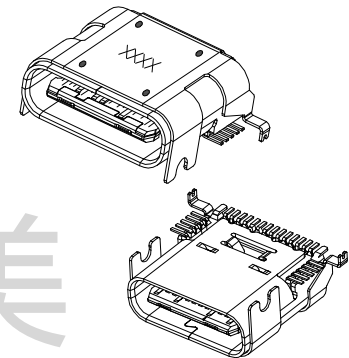

- NOTES:
- ELECTRICAL:
 - CONTACT CURRENT RATING 5.0A FOR VBUS AND GND(PINS A4 A9 B4 B9)
 - INSULATION RESISTANCE: 100 MEGAOHMS MIN. AT 250VDC.
 - DIELECTRIC WITHSTANDING VOLTAGE: 100VAC MIN.
 - LOW CONTACT RESISTANCE: INITIAL 40mΩ MAX. AFTER 50mΩ MAX.
 - MECHANICAL CHARACTERISTICS:
 - INSERTION FORCE: 5N~20N.
 - EXTRACTION FORCE: 8N~20N FORM 1 TO 1000CYCLES. 6~20N FORM 1001 TO 10000CYCLES.
 - DURABILITY: 10,000 MATING CYCLES
 - OPERATING TEMPERATURE: -55°C TO +85°C
 - COPLANARITY: 0.10MAX.

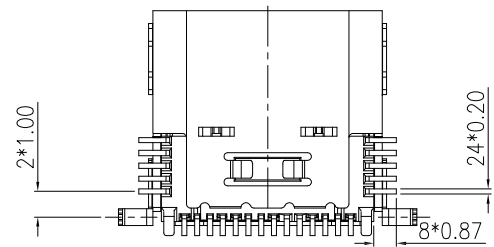

G-Switch Electronic Technology CO.,Ltd.

Unless otherwise specified, Tolerance:
 X. ±0.30
 X.x ±0.20
 X.xx ±0.15
 X.xxx ±0.10
 Angles ±3°

DESIGN 陈锋枫 DATE 2016.05.29
 CHECKED DATE
 APPROVED DATE
<http://www.dg-switch.com>
 TEL:0769-82388879

TITLE:
GT-USB-7024A
 REV.: X1 SCALE: 4:1 UNIT: mm
 SIZE: A4 SHEET: 1/1

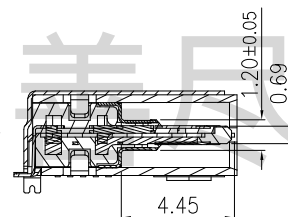
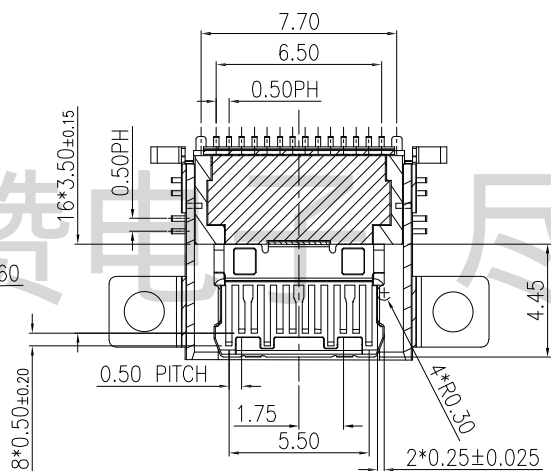
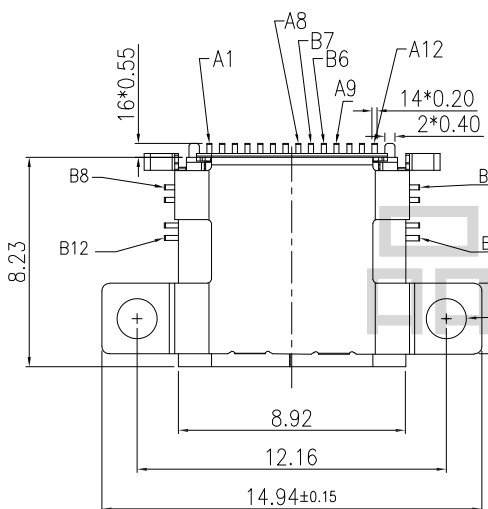
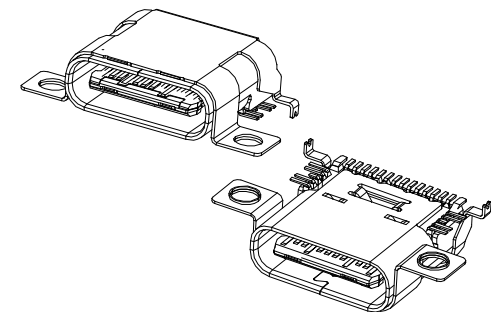
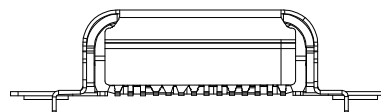
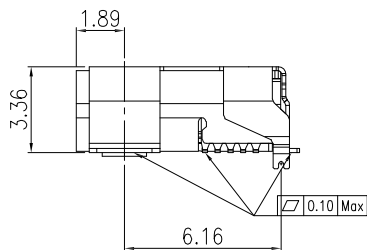
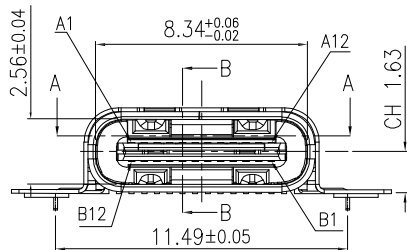

SECTION B-B
SCALE 1-1

SECTION A-A
SCALE 1-1

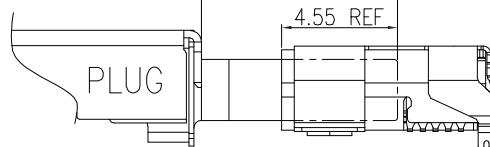

MATING INTERFACE

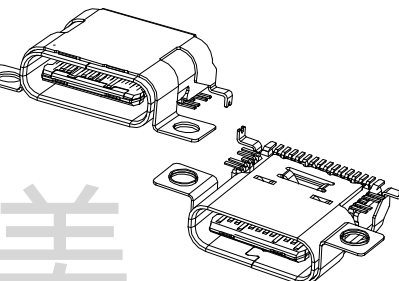
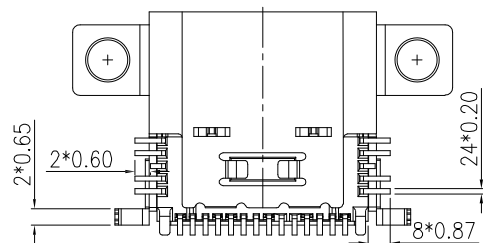

NOTES:

- ELECTRICAL:
 - CONTACT CURRENT RATING 5.0A FOR VBUS AND GND(PINS A4 A9 B4 B9)
 - INSULATION RESISTANCE: 100 MEGAOHMS MIN. AT 250VDC.
 - DIELECTRIC WITHSTANDING VOLTAGE: 100VAC MIN.
 - LOW CONTACT RESISTANCE: INITIAL 40mΩ MAX. AFTER 50mΩ MAX.
- MECHANICAL CHARACTERISTICS:
 - INSERTION FORCE: 5N~20N.
 - EXTRACTION FORCE: 8N~20N FORM 1 TO 1000CYCLES. 6~20N FORM 1001 TO 10000CYCLES.
 - DURABILITY: 10,000 MATING CYCLES
 - OPERATING TEMPERATURE: -55°C TO +85°C
- COPLANARITY: 0.10MAX.



RoHS
Compliant
2002/95/EC



G-Switch Electronic Technology CO.,Ltd.

Unless otherwise specified, Tolerance:
X. ±0.30
X.x ±0.20
X.xx ±0.15
X.xxx ±0.10
Angles ±3°

DESIGN 陈锋枫 DATE 2016.05.29
CHECKED DATE
APPROVED DATE
<http://www.dg-switch.com>
TEL:0769-82388879

TITLE:
GT-USB-7024B
REV.: X1 SCALE: 4:1 UNIT: mm
SIZE: A4 SHEET: 1/1

