

GT-TC177X-H050-L1

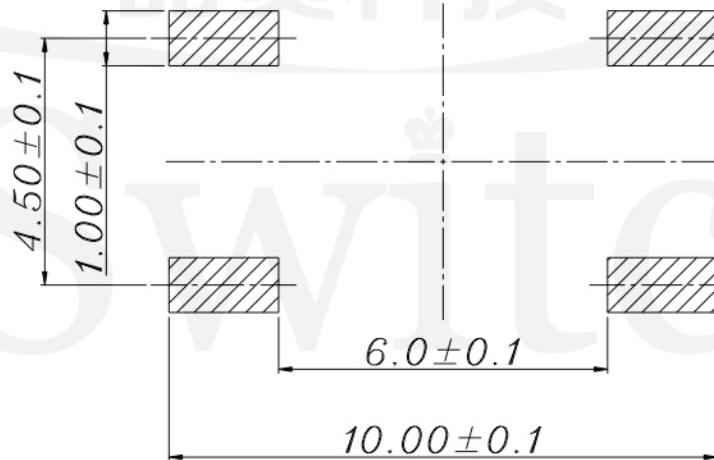
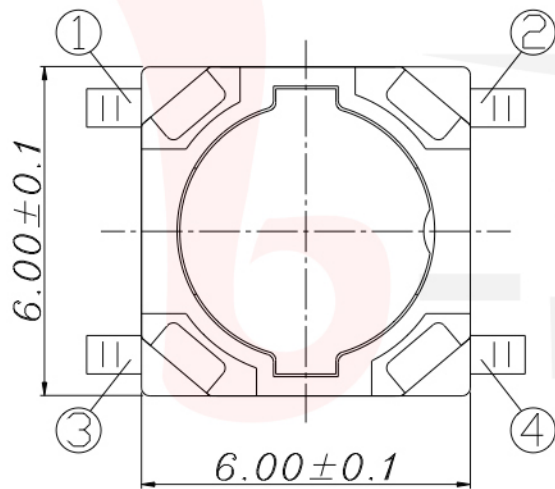

P.C.B LAND DIMENSION

G-SWITCH

Operating Force
A=200gf
B=350gf

Switch Height
H050=5.0mm

Switch lifetime (Force)
L1=100,000 Cycles (A)
L03=30,000 Cycles (B)

G-Switch Specification:

Operating temperature range: -30°C to +85°C

Rating: 50mA, 12V DC

Insulation resistance: 100MΩ min, 100V DC

Dielectric strength: 250V AC for 1 min

Contact resistance: 100mΩ max.

Travel: 1.3±0.1mm

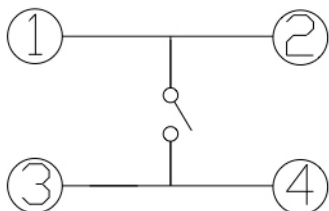

CIRCUIT DIAGRAM



		G-Switch Electronic (HongKong) CO.,Ltd.				
				DESIGN 陈锋枫	DATE 2019.05.29	Molde code:
Unless otherwise specified, Tolerance: X. ±0.30 X.x ±0.20 X.xx ±0.15 X.xxx ±0.10 Angles ±3°		CHECKED	DATE	GT-TC177X-H050-LX		
		APPROVED	DATE			
		http://www.dg-switch.com		REV.: X1	SCALE: 4:1	UNIT: mm
		TEL: 0769-82388879		SIZE: A4	SHEET: 1/1	