

GT-TC022X-HXXX-LX

G-SWITCH

Operating Force
A=160gf
B=250gf

Switch Height (mm)
H035=3.5mm

Switch lifetime (Force)
L1=100,000 Cycles

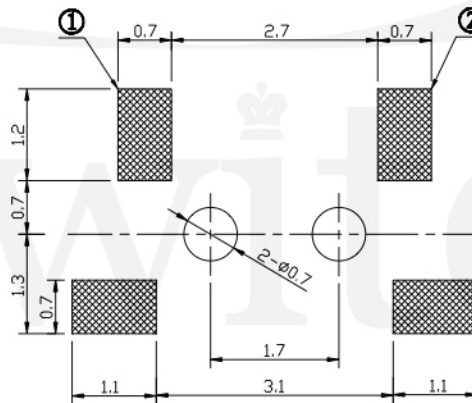
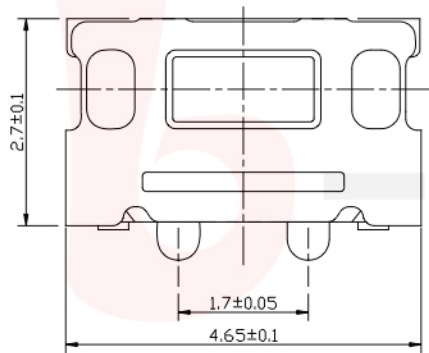

P.C.B LAND DIMENSION

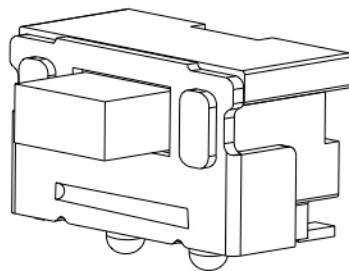

CIRCUIT DIAGRAM

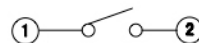

G-Switch Specification:

Operating temperature range : -30°Cto+85°C
 Rating : 50mA.12V DC
 Insulation resistance: : 100MΩ min.100V DC
 Dielectric strength : 250V AC for 1 min
 Contact resistance: : 100m Ω max.
 Travel:0.15±0.05mm

	G-Switch Electronic (HongKong) CO.,Ltd.		
	DESIGN FengFengChen	DATE 2019.05.29	Molde code:
Unless otherwise specified, Tolerance:	CHECKED	DATE	GT-TC022X-HXXX-LX
X. ±0.30	APPROVED	DATE	
X.x ±0.20	http://www.dg-switch.com		REV.: X1
X.xx ±0.15	TEL:0769-82388879		SCALE: 4:1
X.xxx ±0.10			UNIT: mm
Angles ±3°			SIZE: A4
			SHEET: 1/1