

GT-TC056X-HXXX-LX

G-SWITCH

Operating Force
 A=160gf
 B=250gf
 C=130gf

Switch Height (mm)
 H043=4.3mm (L3.15)
 H050=5.0mm (L3.85)

Switch lifetime (Force)
 L03=30,000 Cycles
 L05=50,000 Cycles

G-Switch Specification:

Operating temperature range : -30°Cto+85°C
 Rating : 50mA.12V DC
 Insulation resistance: : 100MΩ min.100V DC
 Dielectric strength : 250V AC for 1 min
 Contact resistance: : 100m Ω max.
 Travel:0.25±0.1mm

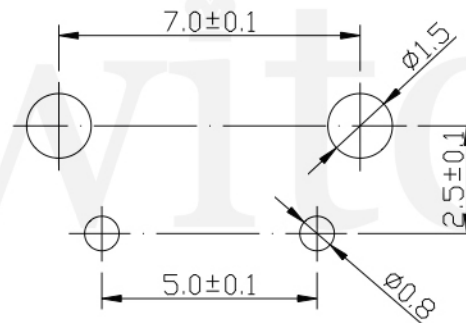
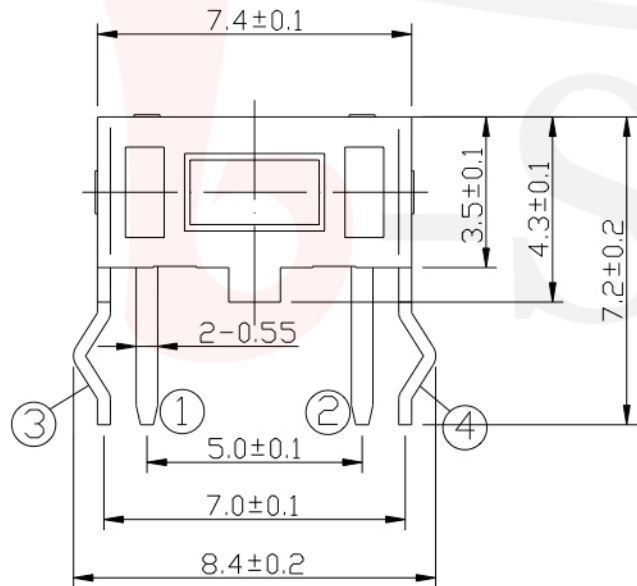

P.C.B LAND DIMENSION

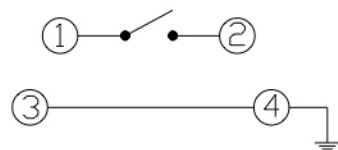

CIRCUIT DIAGRAM



	G-Switch Electronic (HongKong) CO.,Ltd.		
	DESIGN FengFengChen CHECKED APPROVED http://www.dg-switch.com TEL:0769-82388879	DATE 2019.05.29 DATE DATE http://www.dg-switch.com	Molde code: GT-TC056X-HXXX-LX REV.: X1 SCALE: 4:1 UNIT: mm SIZE: A4 SHEET: 1/1