

GT-TC151X-HXXX-LX

G-SWITCH

Operating Force
 A=160gf
 B=250gf
 C=100gf

Switch Height (mm)
 H073=7.3mm

Switch lifetime (Force)
 L05=50,000 Cycles
 L1=100,000 Cycles
 L3=300,000 Cycles
 L5=500,000 Cycles

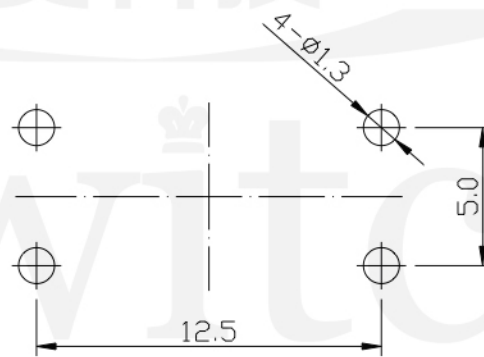
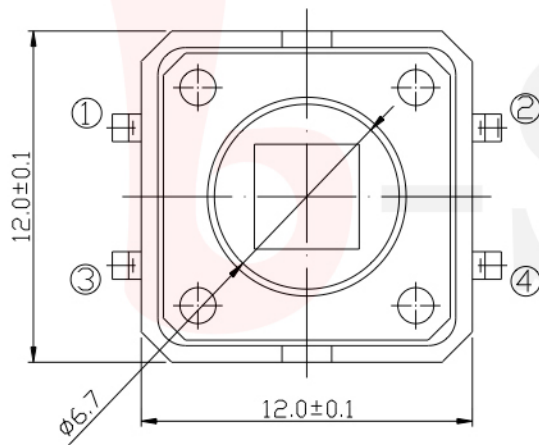

P.C.B LAND DIMENSION

G-Switch Specification:

Operating temperature range : -30°Cto+85°C
 Rating : 50mA.12V DC
 Insulation resistance : 100MΩ min.100V DC
 Dielectric strength : 250V AC for 1 min
 Contact resistance : 100m Ω max.
 Travel:0.25±0.1mm

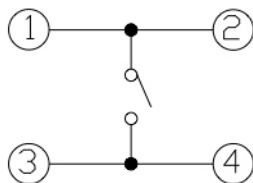

CIRCUIT DIAGRAM



G-Switch Electronic (HongKong) CO.,Ltd.

Unless otherwise specified, Tolerance:
 X. ±0.30
 X.x ±0.20
 X.xx ±0.15
 X.xxx ±0.10
 Angles ±3°

DESIGN FengFengChen DATE 2019.05.29
 CHECKED DATE
 APPROVED DATE
<http://www.dg-switch.com>
 TEL:0769-82388879

Molde code:
GT-TC151X-HXXX-LX
 REV.: X1 SCALE: 4:1 UNIT: mm
 SIZE: A4 SHEET: 1/1