

### GT-TC188X-HXXX-LX

MODEL	L (mm)	M (mm)
A	3.8	3.0
B	3.3	2.5

G-SWITCH



**Operating Force**  
 A=160gf  
 B=250gf  
 C=100gf

**Switch Height (mm)**  
 H625=6.25mm

**Switch lifetime (Force)**  
 L05=50,000 Cycles

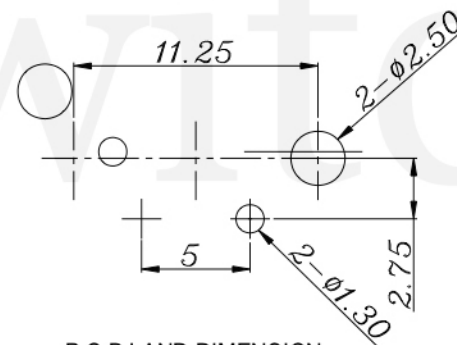
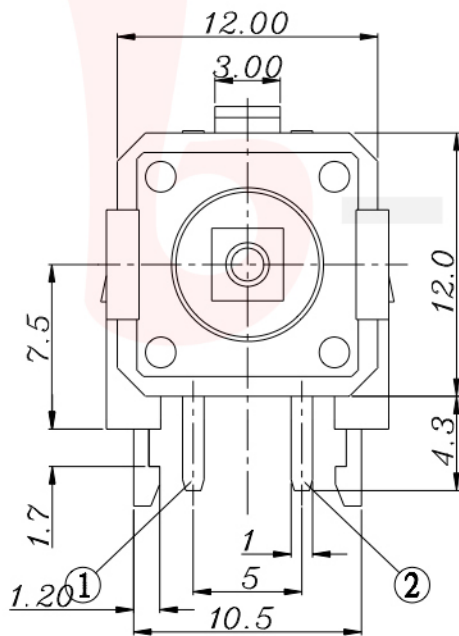

P.C.B LAND DIMENSION

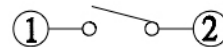

CIRCUIT DIAGRAM



**G-Switch Specification:**

Operating temperature range : -30°Cto+85°C  
 Rating : 50mA.12V DC  
 Insulation resistance: : 100MΩ min.100V DC  
 Dielectric strength : 250V AC for 1 min  
 Contact resistance: : 100m Ω max.  
 Travel:0.25±0.1mm

	<b>G-Switch Electronic (HongKong) CO.,Ltd.</b>		
	DESIGN FengFengChen	DATE 2019.05.29	Molde code: <b>GT-TC188X-HXXX-LX</b>
	CHECKED	DATE	
	APPROVED	DATE	REV.: X1 SCALE: 4:1 UNIT: mm SIZE: A4 SHEET: 1/1
Unless otherwise specified, Tolerance: X. ±0.30 X.x ±0.20 X.xx ±0.15 X.xxx ±0.10 Angles ±3°		<a href="http://www.dg-switch.com">http://www.dg-switch.com</a> TEL:0769-82388879	