

印制线路板
Recommended P.C.B layout

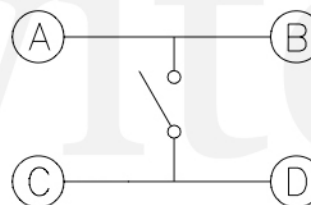

电路简图
SCHEMATIC

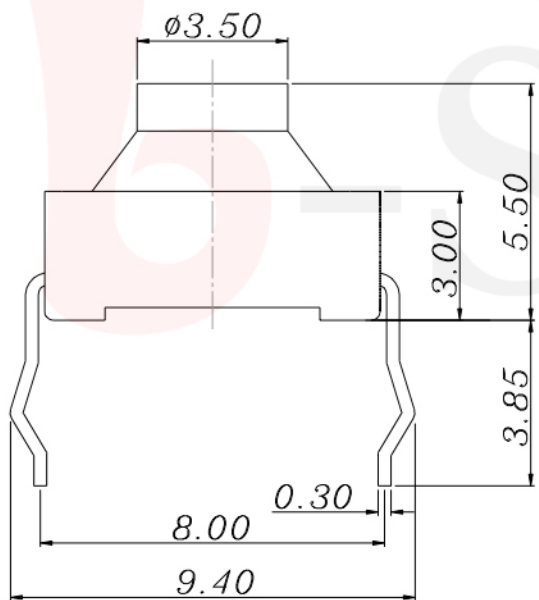

GT-TC156X-HXXX-LX

G-SWITCH

Operating Force
A=160gf
B=250gf
C=100gf

Switch Height (mm)
H055=5.5mm

Switch lifetime (Force)
L1=100,000 Cycles

G-Switch Specification:

Operating temperature range : -30°Cto+85°C
Rating : 50mA.12V DC
Insulation resistance: : 100MΩ min.100V DC
Dielectric strength : 250V AC for 1 min
Contact resistance: : 100m Ω max.
Travel:1.2±0.1mm



G-Switch Electronic (HongKong) CO.,Ltd.

Unless otherwise specified, Tolerance:
X. ±0.30
X.x ±0.20
X.xx ±0.15
X.xxx ±0.10
Angles ±3°

DESIGN FengFengChen DATE 2019.05.29
CHECKED DATE
APPROVED DATE
<http://www.dg-switch.com>
TEL:0769-82388879

Molde code:
GT-TC156X-HXXX-LX
REV.: X1 SCALE: 4:1 UNIT: mm
SIZE: A4 SHEET: 1/1