

PS-8080D-6PX

X=NO LOCK
L=LOCK

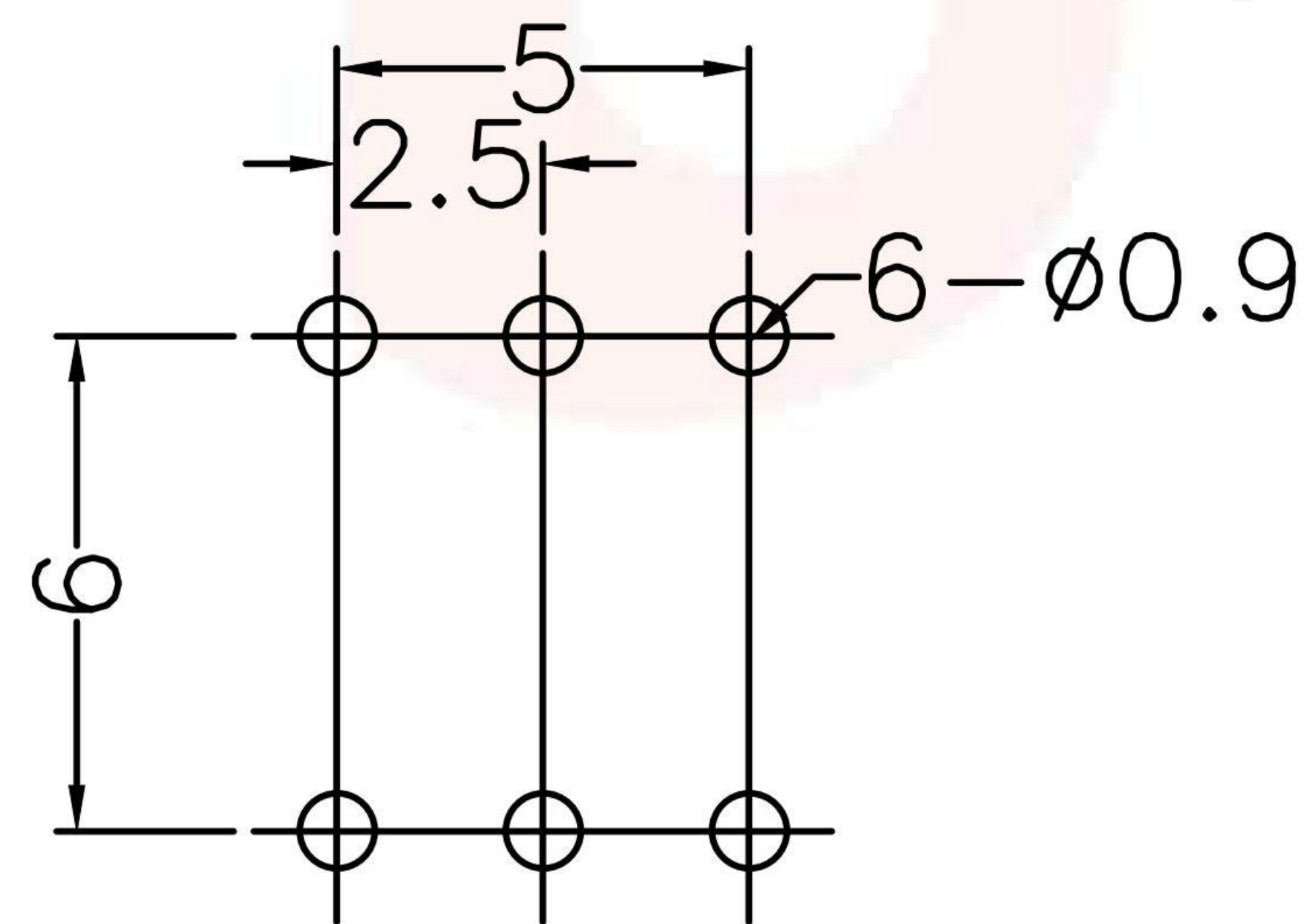

P.C.B LAYOUT
BOTTOM VIEW

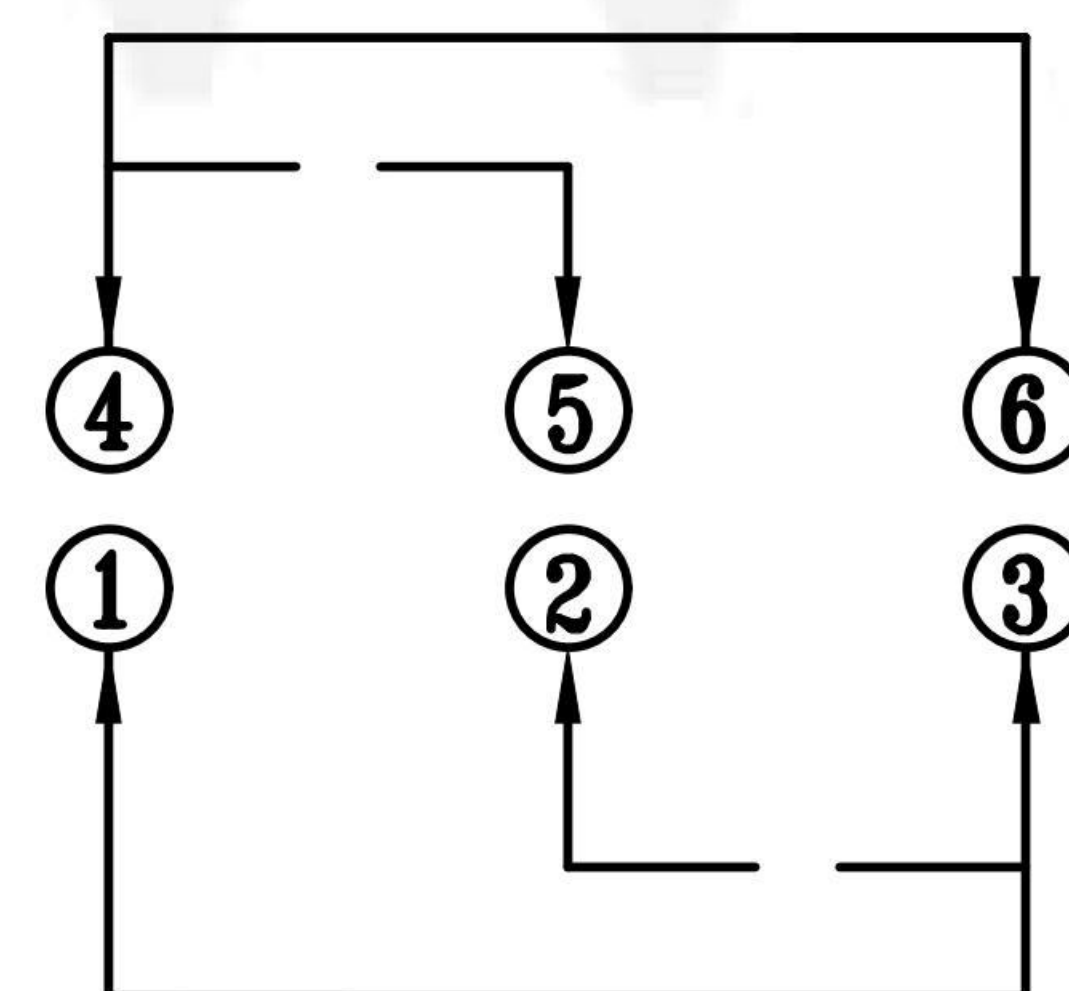

SCHEMATIC

G-Switch Specification:

Electrical Specifications: 0.5A 30VDC
 Contact Resistance : ≤100mΩ
 Insulation Resistance: ≥100MΩ DC125V
 Withstand Voltage: AC125V 1 minute
 Operating Temperature: -25°C~+65°C
 Storage Humidity: ≤85%RH
 Electrical Life: 10,000
 Mechanical Life: 100,000

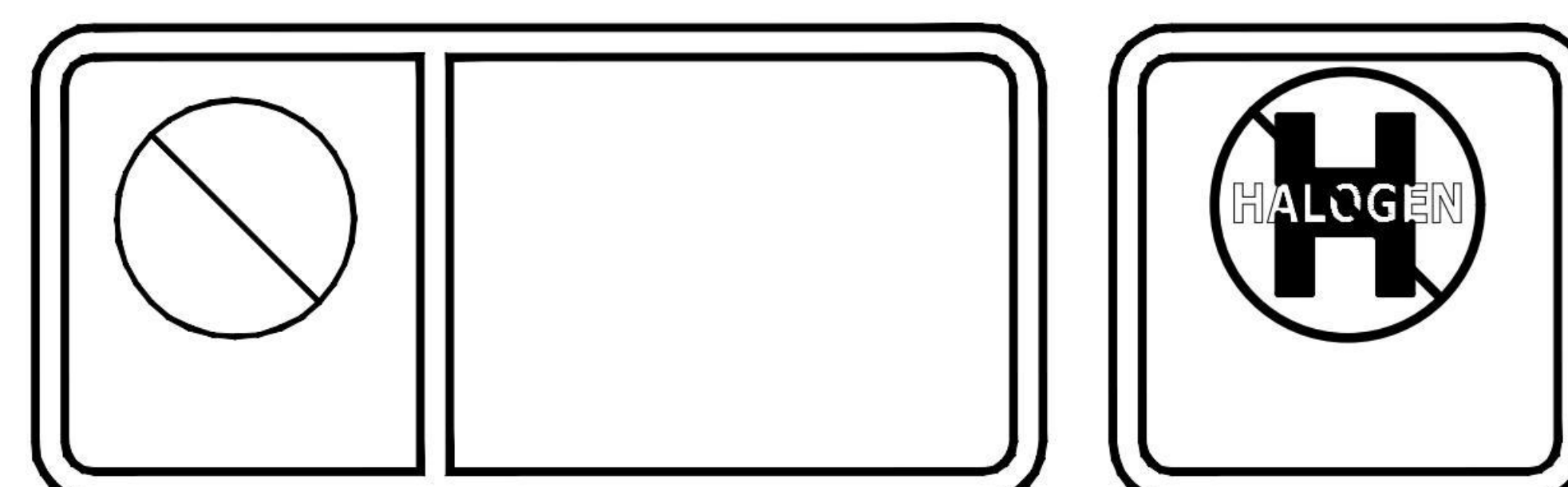

	G-Switch Electronic (HongKong) CO.,Ltd.		
	Unless otherwise specified, Tolerance: X. ±0.30 X.x ±0.20 X.xx ±0.15 X.xxx ±0.10 Angles ±3°	DESIGN Yvette Chen CHECKED APPROVED http://www.dg-switch.com TEL:0769-82388879	DATE 2019.05.29 DATE DATE REV.: X1 SIZE: A4