

GT-TA113X-HXXX-LX

G-SWITCH

Operating Force
 A=160gf
 B=250gf
 C=100gf

Switch Height (mm)
 H043=4.3mm
 H080=8.0mm
 H085=8.5mm

Switch lifetime (Force)
 L100=10,000,000 Cycles

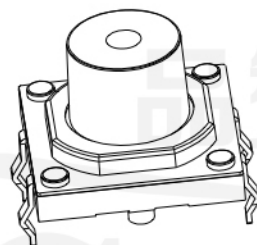
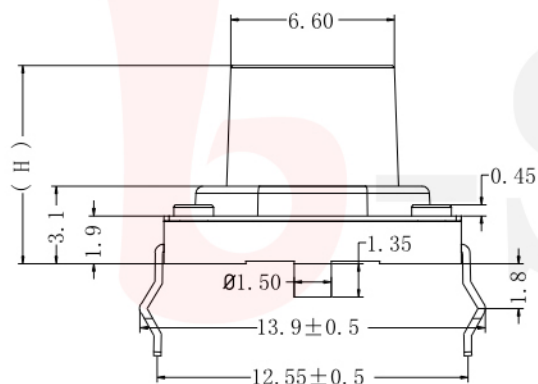

品贊科技

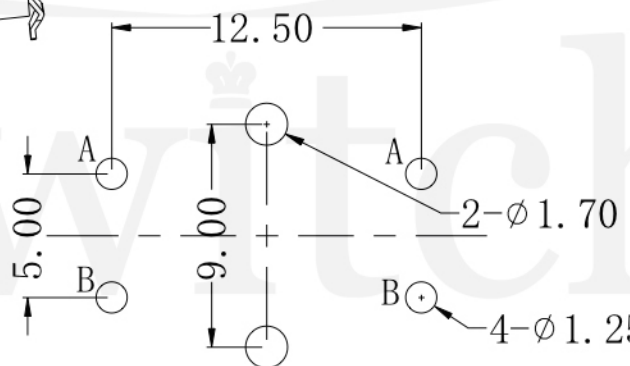

P.C.B LAND DIMENSION

G-Switch Specification:

Operating temperature range : -30°Cto+85°C
 Rating : 50mA.12V DC
 Insulation resistance : : 100MΩ min.100V DC
 Dielectric strength : 250V AC for 1 min
 Contact resistance : : 100m Ω max.
 Travel:0.30±0.1mm
 WATER RESISTANCE IP67

Circuit Diagram

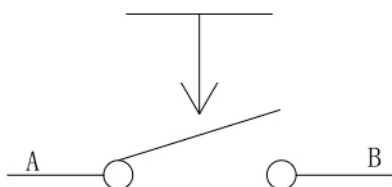

	G-Switch Electronic (HongKong) CO.,Ltd.		
	DESIGN FengFengChen CHECKED ZH APPROVED http://www.dg-switch.com TEL:0769-82388879	DATE 2020.05.29 DATE DATE	Molde code: GT-TA113X-HXXX-LX REV.: X1 SCALE: 4:1 UNIT: mm SIZE: A4 SHEET: 1/1
Unless otherwise specified, Tolerance: X. ±0.30 X.x ±0.20 X.xx ±0.15 X.xxx ±0.10 Angles ±3°			

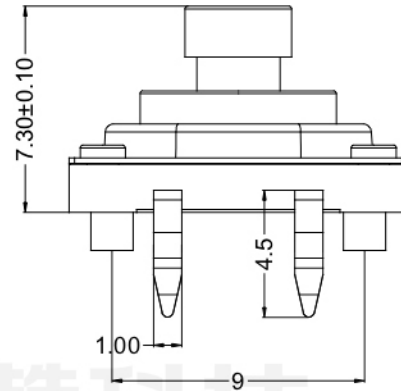
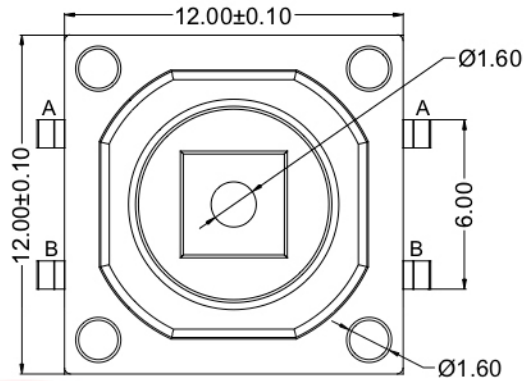

GT-TC113X-H073-LX

G-SWITCH

Operating Force

- A=160gf
- B=250gf
- C=100gf

Switch Height (mm)
H073=7.3mm

Switch lifetime (Force)
L100=10,000,000 Cycles

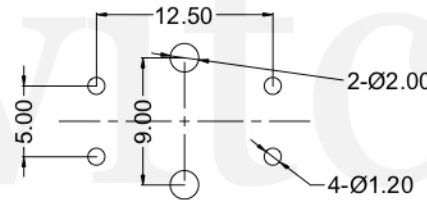
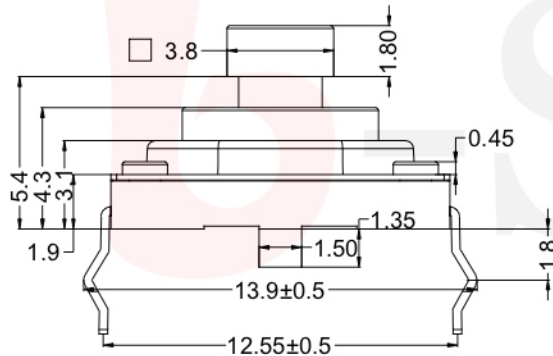

P.C.B LAND DIMENSION

G-Switch Specification:

Operating temperature range : -30°Cto+85°C
 Rating : 50mA.12V DC
 Insulation resistance : 100MΩ min.100V DC
 Dielectric strength : 250V AC for 1 min
 Contact resistance : 100m Ω max.
 Travel:0.30±0.1mm
 WATER RESISTANCE IP67

Circuit Diagram



	G-Switch Electronic (HongKong) CO.,Ltd.		
	DESIGN FengFengChen	DATE 2020.05.29	Molde code:
Unless otherwise specified, Tolerance:	CHECKED ZH	DATE	GT-TC113X-H073-LX
X. ±0.30	APPROVED	DATE	
X.x ±0.20	http://www.dg-switch.com		REV.: X1
X.xx ±0.15	TEL:0769-82388879		SCALE: 4:1
X.xxx ±0.10			UNIT: mm
Angles ±3°			SIZE: A4
			SHEET: 1/1