

G-Switch USB-C Specification:

1. Current rated: 5A on vbus/1.25A on vconn/0.25A on other
2. Voltage rating: 24V AC
3. Withstanding voltage: 100V AC/minute
4. Contact resistance: 40mΩ Max
5. Insulation resistance: 100MΩ Min
6. Operating temperature: -40°C ~ +85°C
7. Mating force: 5N~20N
8. Unmating force: 8N~20N
9. Durability cycle: 10,000 cycles
9. Waterproof grade: IP-X7

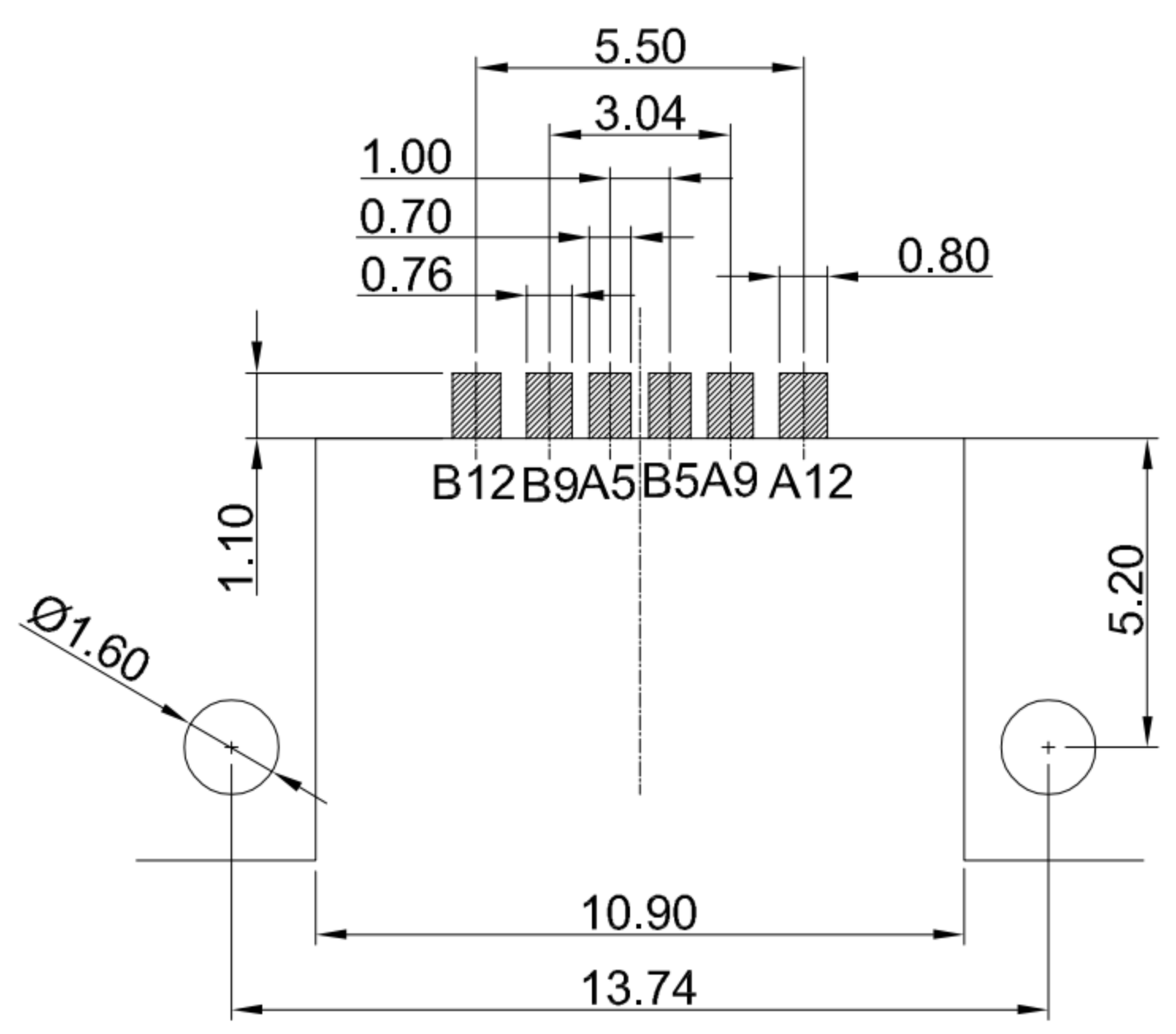

RECOMMENDED PCB LAYOUT
TOLERANCE: ±0.05

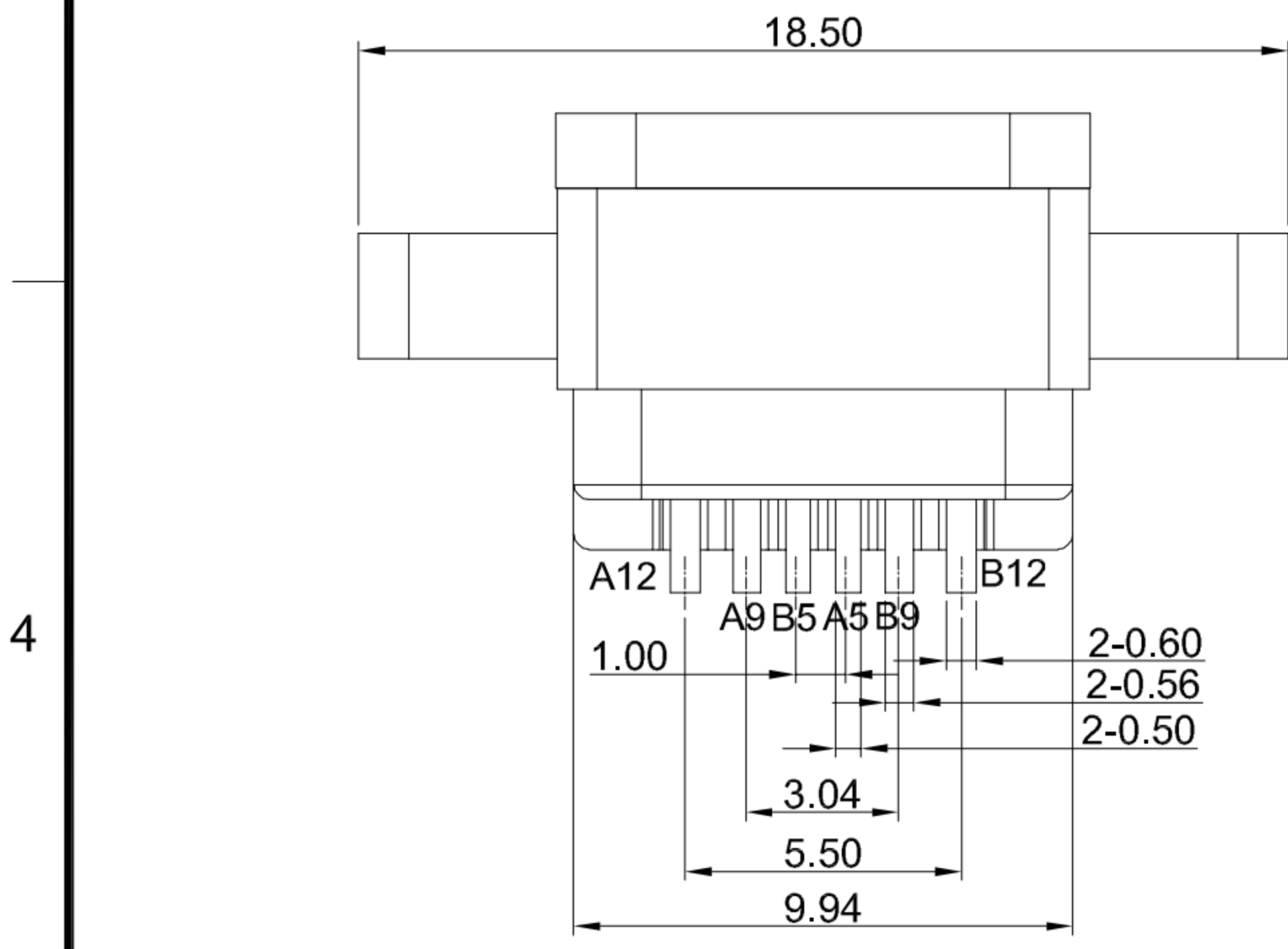
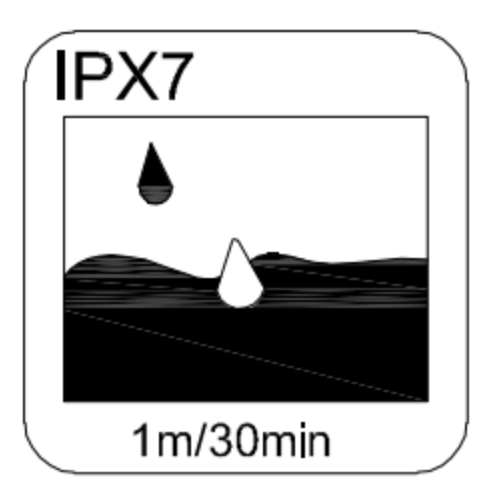

A1	A2	A3	A4	A5	A6	A7	A8	A9	A10	A11	A12
				CC1				VBUS			GND
				Second				First			First
B12	B11	B10	B9	B8	B7	B6	B5	B4	B3	B2	B1
GND			VBUS				CC2				
First			First				Second				

1	SHELL1	HIGH TEMPERATURE PLASTIC	BLACK UL 94 V-0
2	SHELL2	STAINLESS STEEL	Ni PLATED
3	MID PLATE	STAINLESS STEEL	—
4	HOUSING	HIGH TEMPERATURE PLASTIC	BLACK UL 94 V-0
5	TERMINALS	COPPER ALLOY	Au PLATING ON CONTACT AREA
6	WATERPROOF RING	SILICA GEL	BLACK UL 94 V-0
NO.	PARTS	MATERIAL	REMARKS



SCALE: 1:1 UNIT: mm
 SIZE: A4

Unless otherwise
 General Tolerance:
 X. ±0.25
 X.x ±0.20
 X.xx ±0.15
 X.xxx ±0.10
 X° ±5°

Title: Horizontal Type-c 6P Female
 SMT CH=1.68 L=8.7mm

Molde Code: GT-USB-7042A

DRAWN	CHECKED	APPROVED	DATE
Xia	Chen	Chen	2023.02.31



REV: A0 SHEET: 1/1