

CIRCUIT DIAGRAM

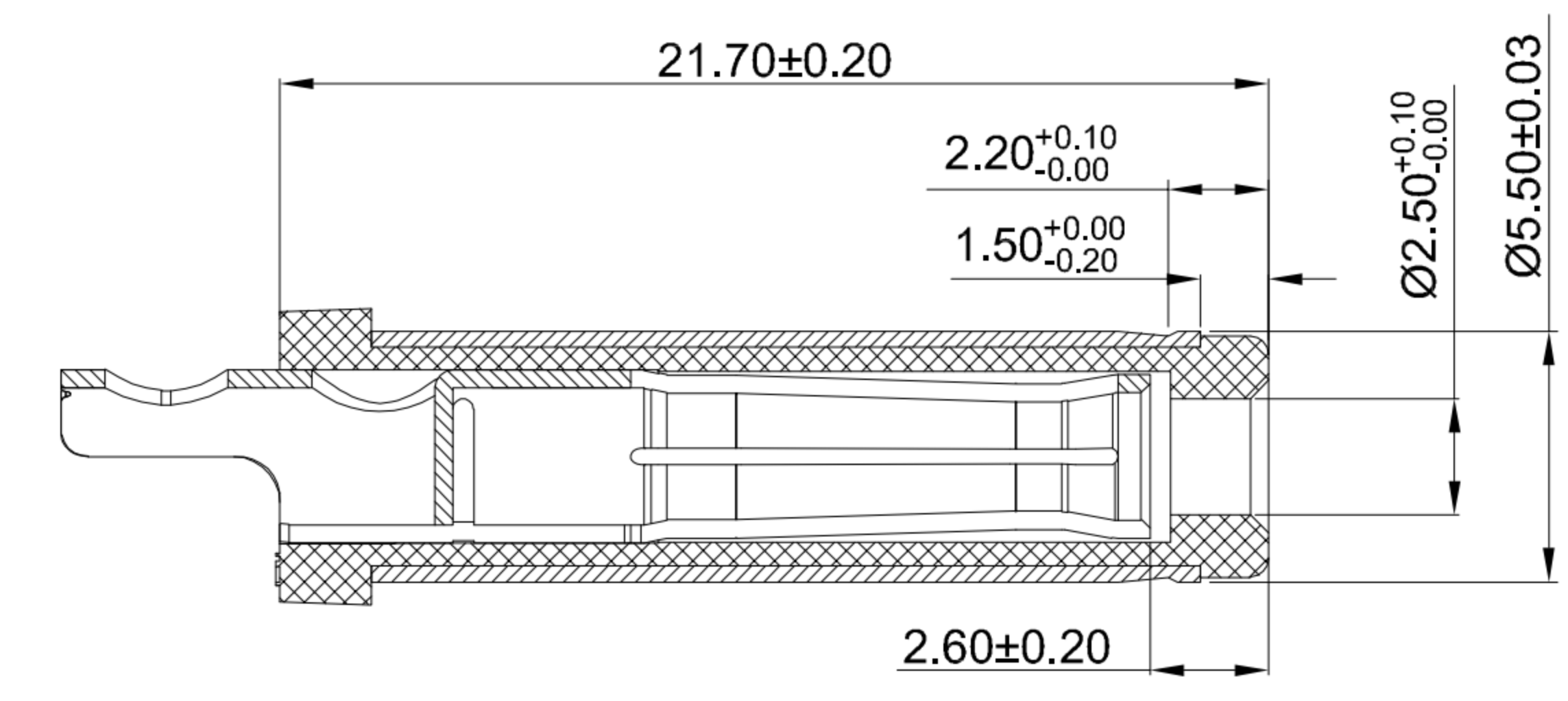

MATING PLUG Ø5.5xØ2.5mm

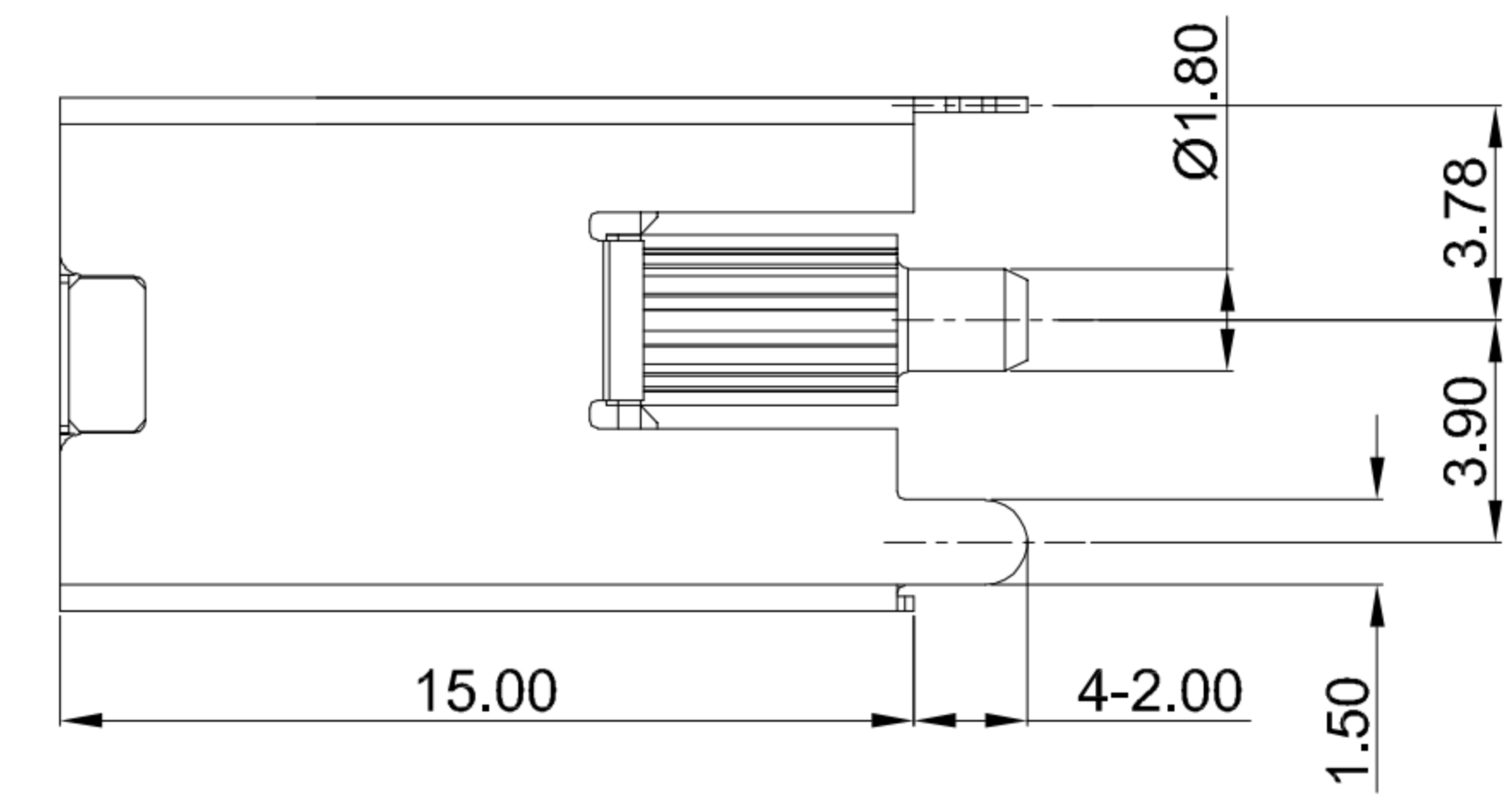
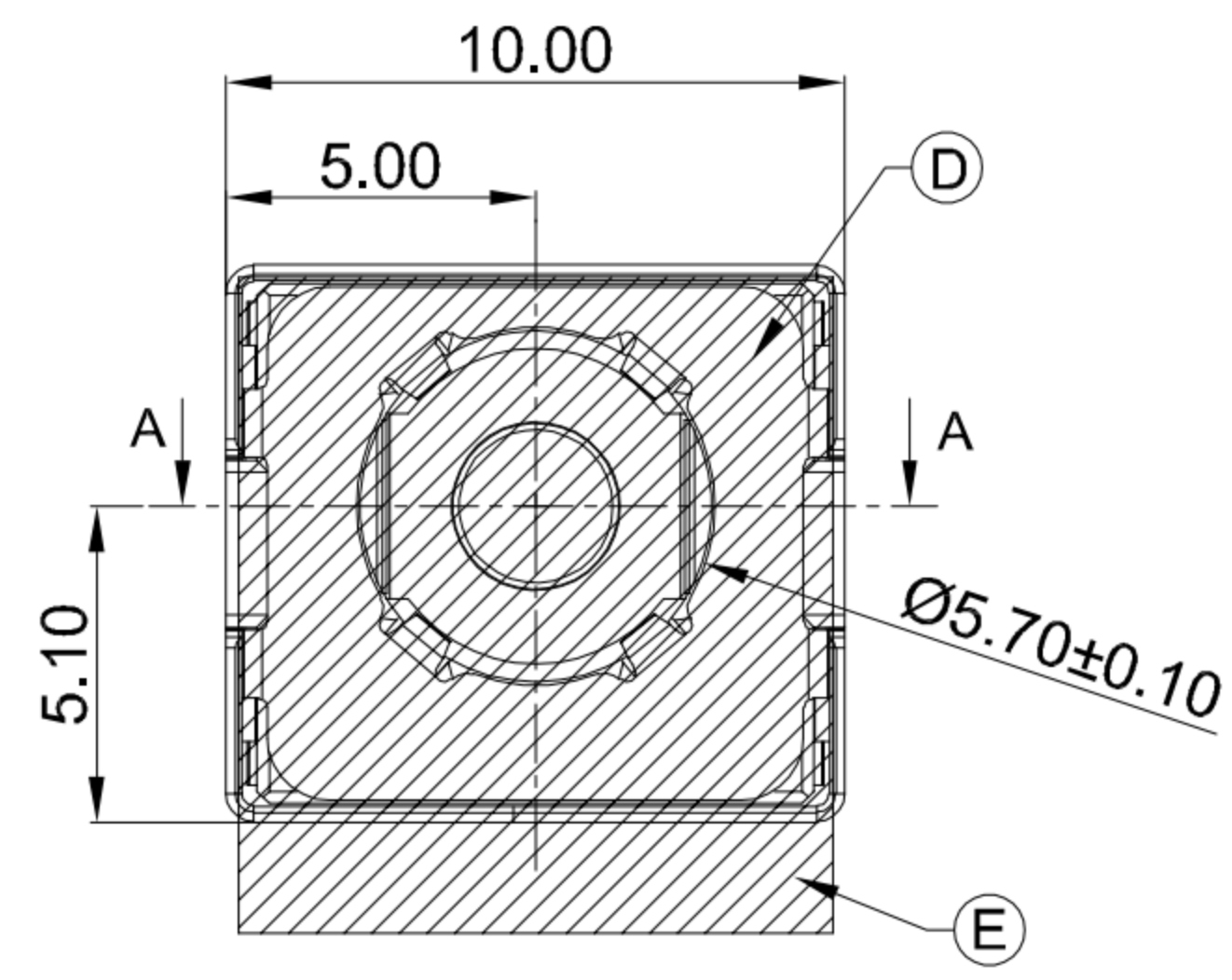
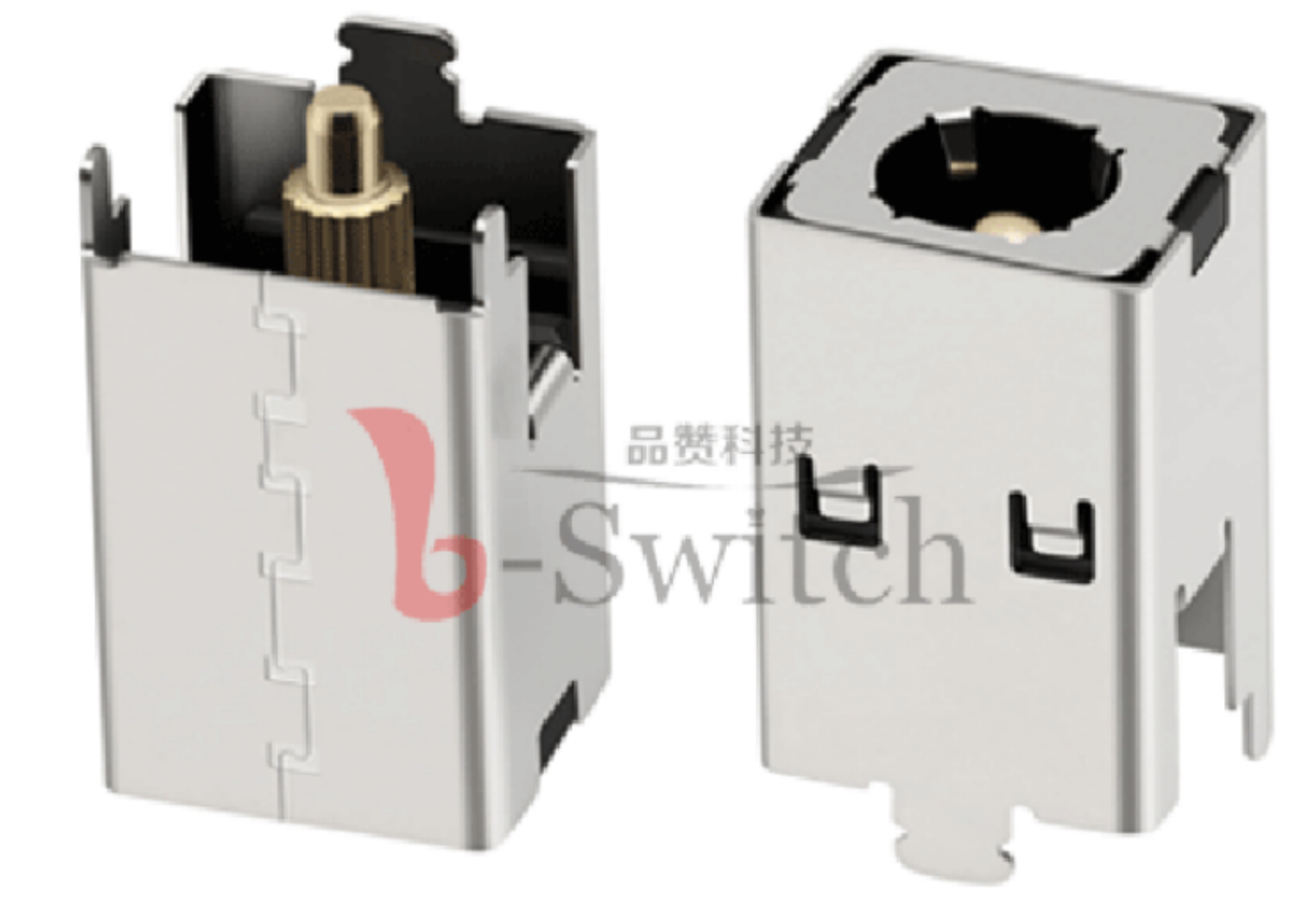
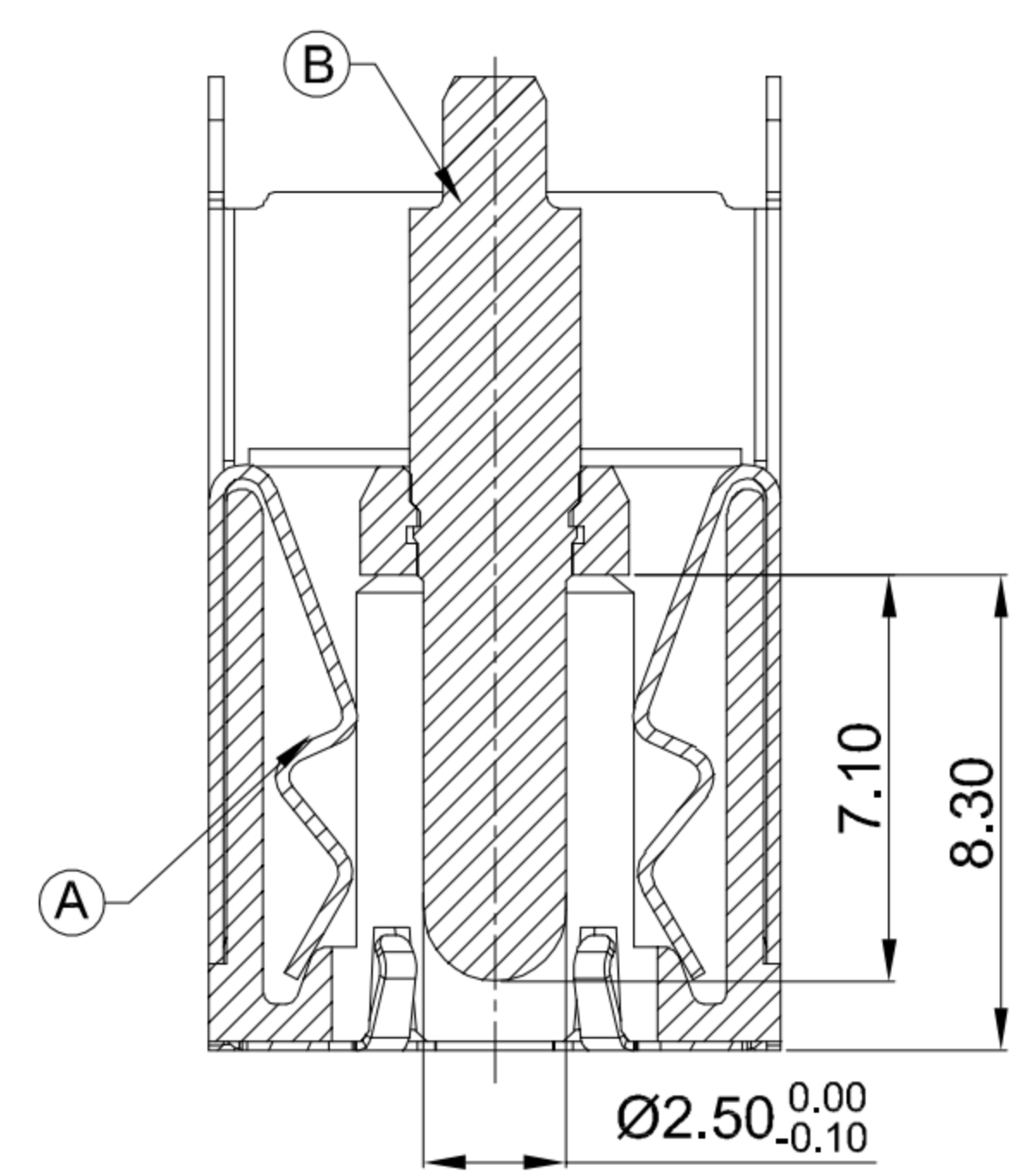

SECTION A-A

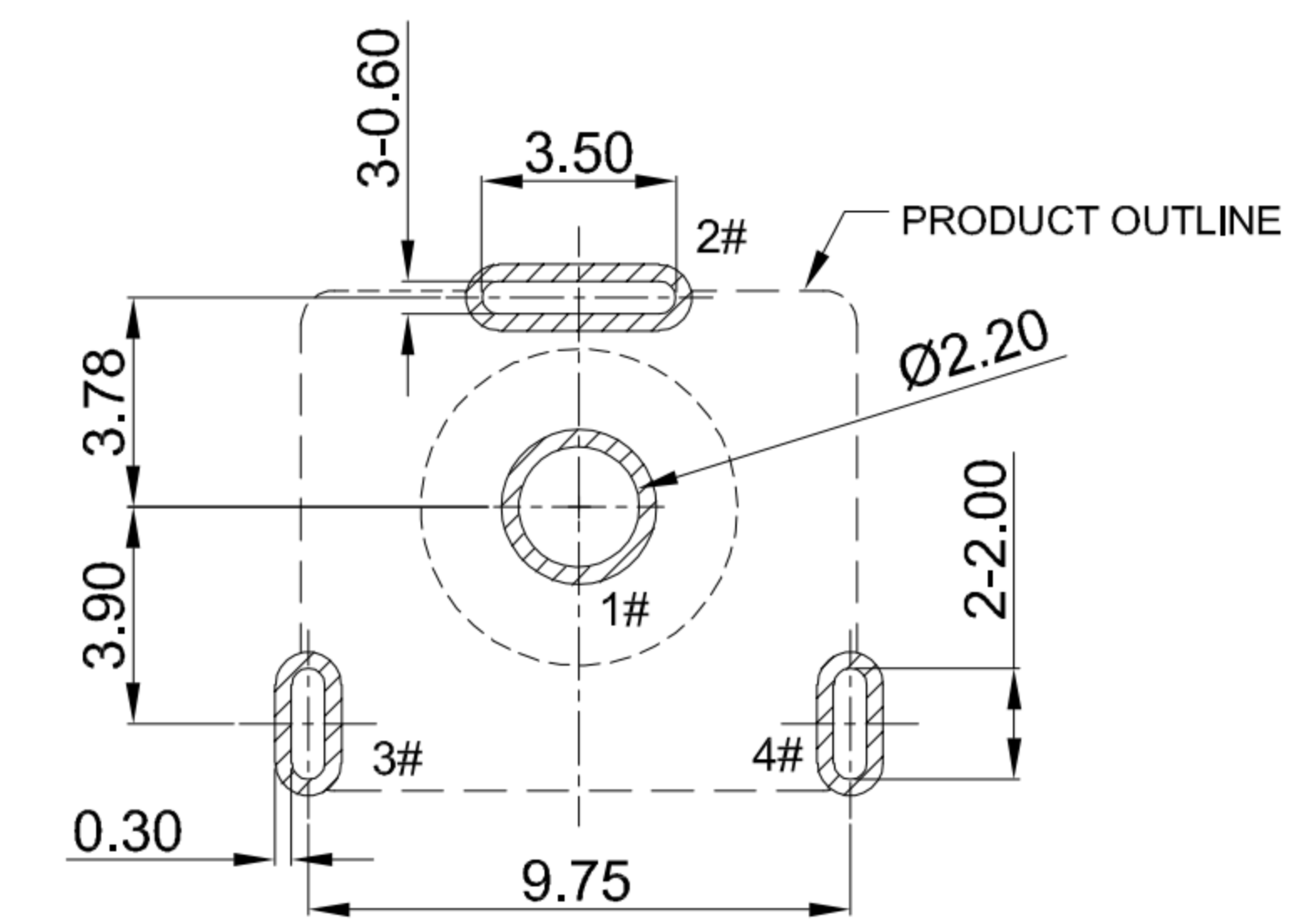

**RECOMMENDED PCB LAYOUT
TOLERANCE: ±0.05**

- G-Switch Specification:**
1. Operating temperature range: -40°C ~ +85°C
 2. Rated load: 20A.20V DC
 3. Insulation resistance: 100MΩ min
 4. Withstand voltage: 500V AC/min
 5. Contact resistance: 30mΩ max(Initial), 50mΩ max(Final)
 6. Durability cycle: 5000 Cycles
 7. Insertion and extraction force: 3-30N

A	HOUSING	HIGH TEMPERATURE PLASTIC	BLACK
B	CENTER PIN	BRASS	GOLD FLASH
C	SHELL	COPPER ALLOY C5210	Ni PLATING
D	GROUND	SUS 304	
E	MYLAR		
NO.	PART NAME	MATERIAL	REMARK



SCALE: 1:1 UNIT: mm
 SIZE: A4

Unless otherwise General tolerance:
 X ±0.50
 X.x ±0.30
 X.xx ±0.20
 X.xxx ±0.10
 X.x° ±3°

Title: Vertical DC Power Jack 5525
 DIP H=15.0 Ø2.5mm

Molde Code: DC-S011F-D025-20A

DRAWN	CHECKED	APPROVED	DATE
Xia	Chen	Chen	2023.02.01



REV: A0 SHEET: 1/1