

1

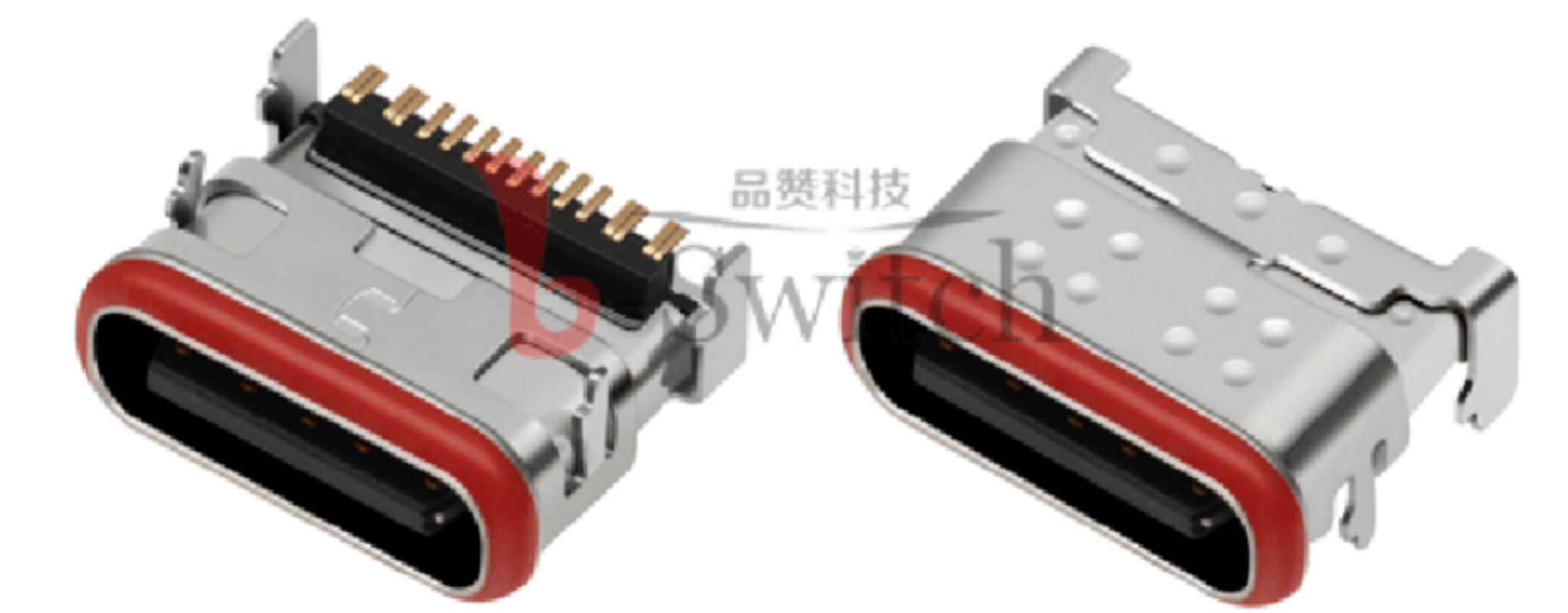

2

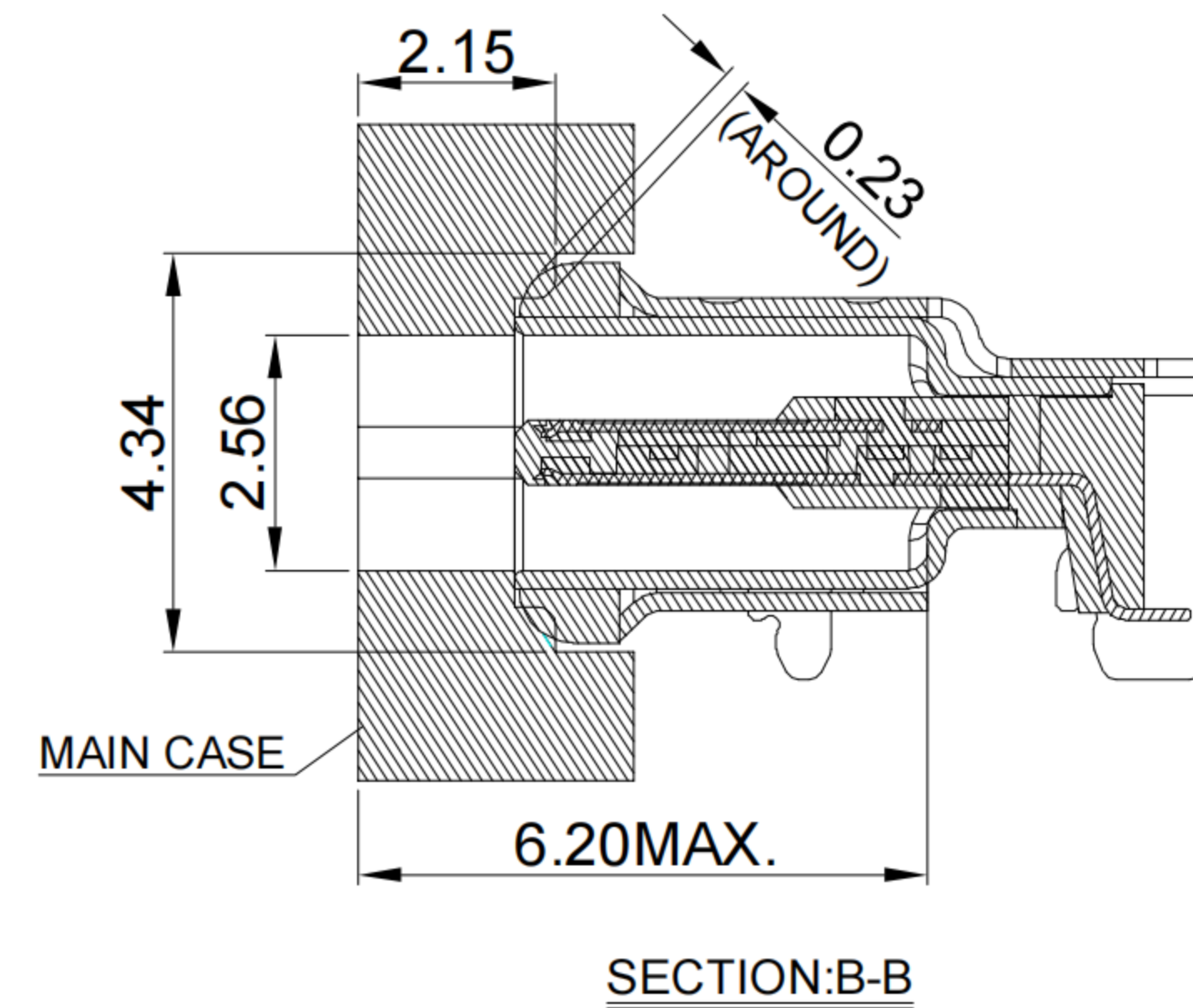
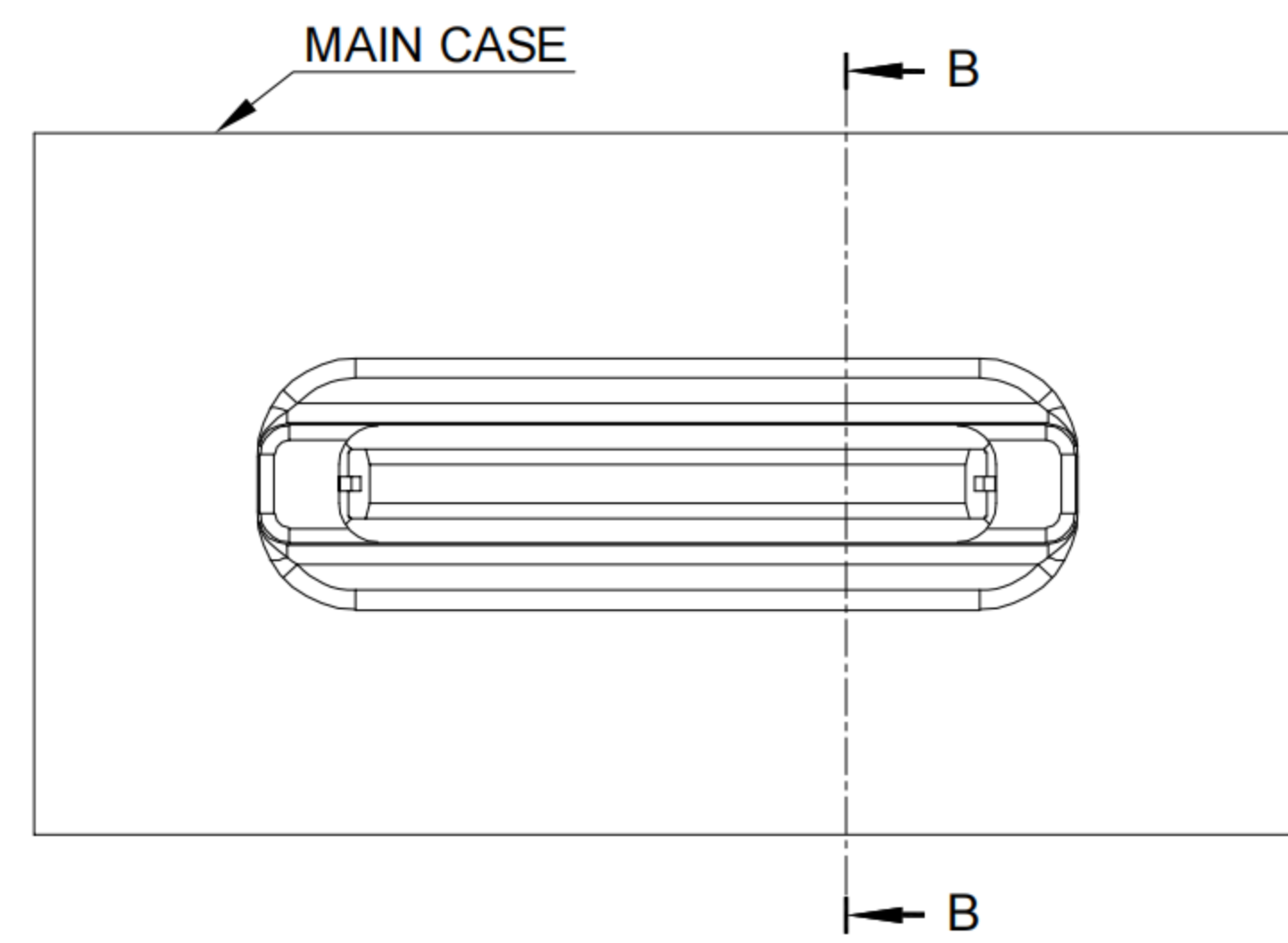
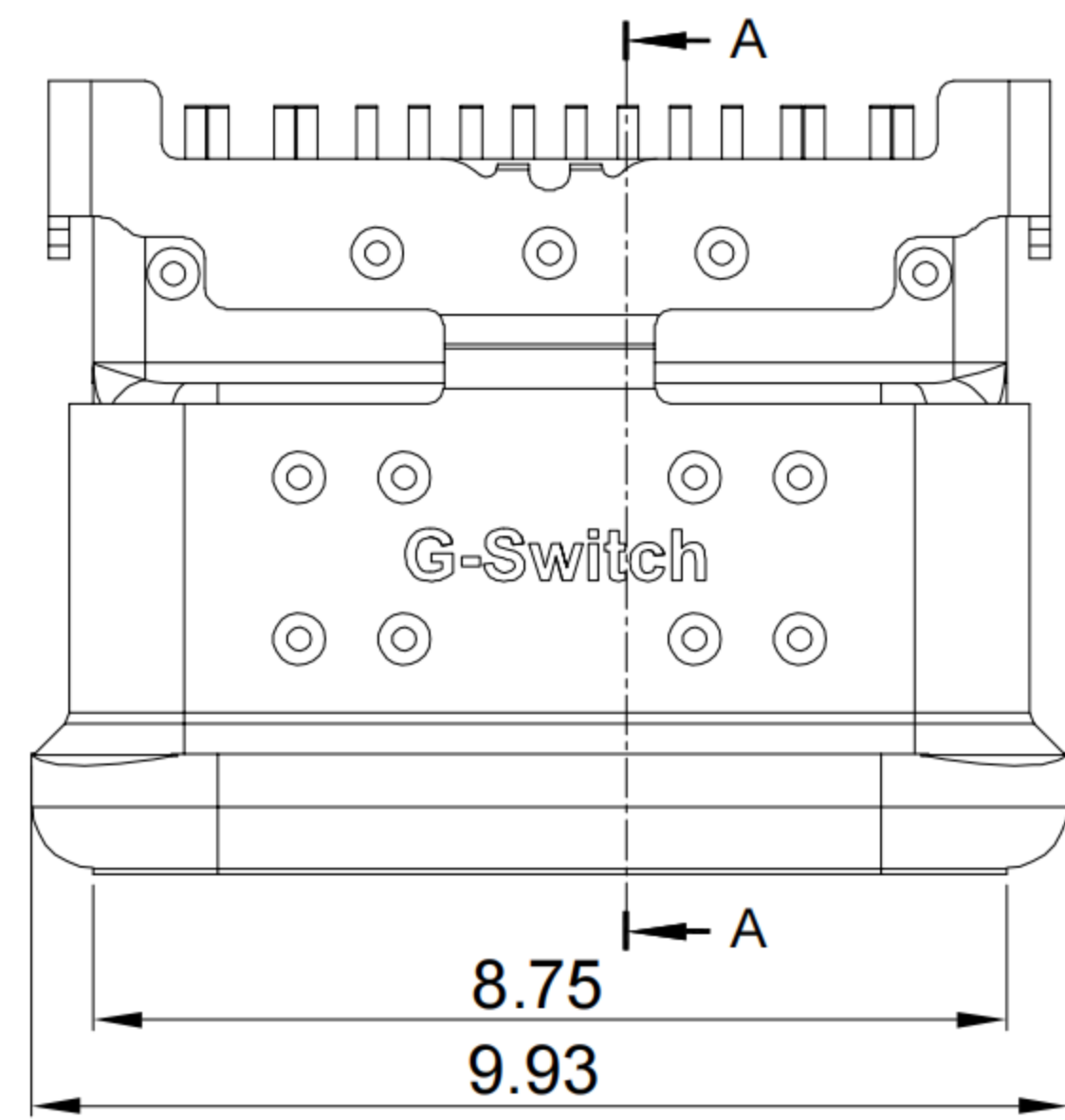
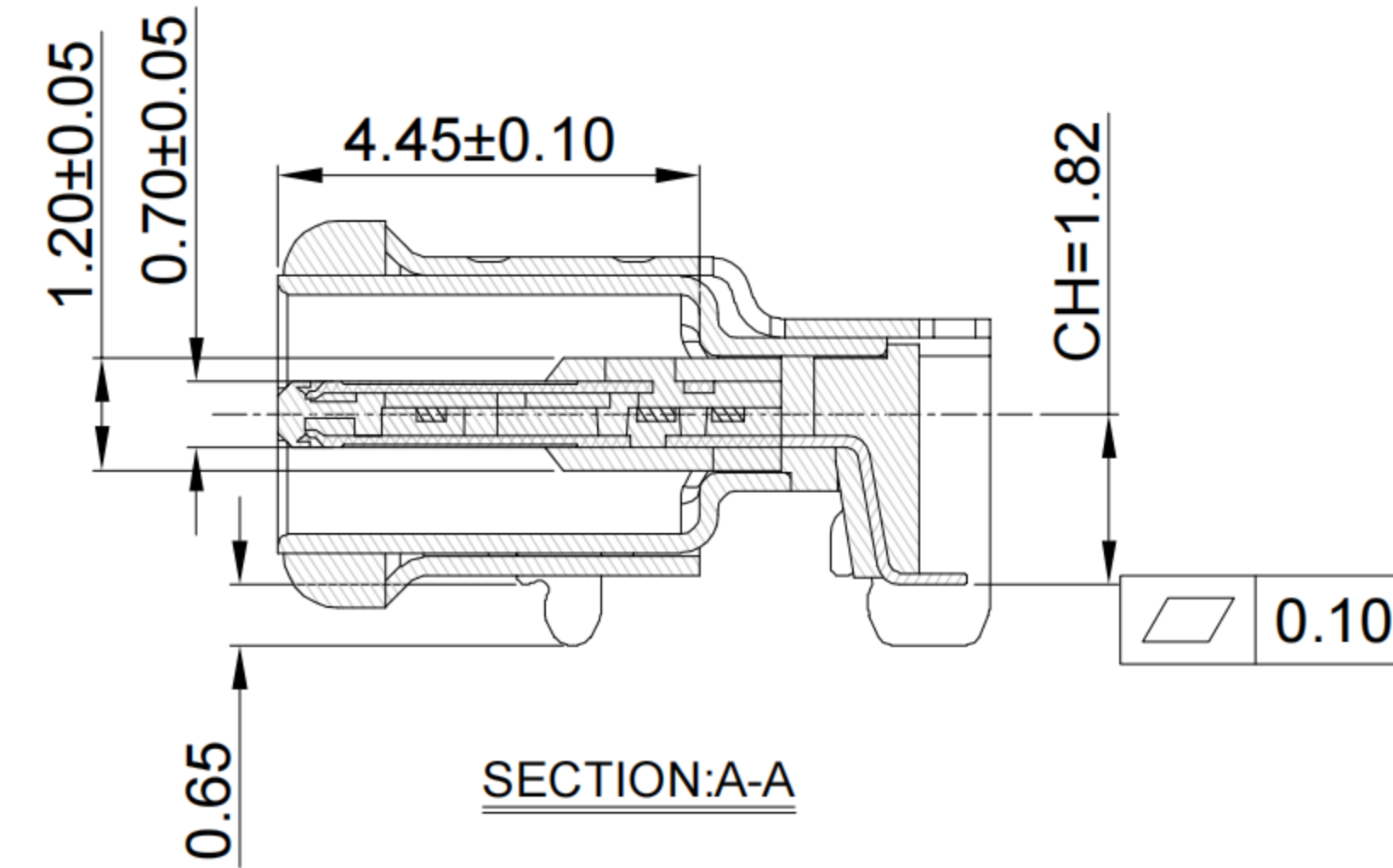
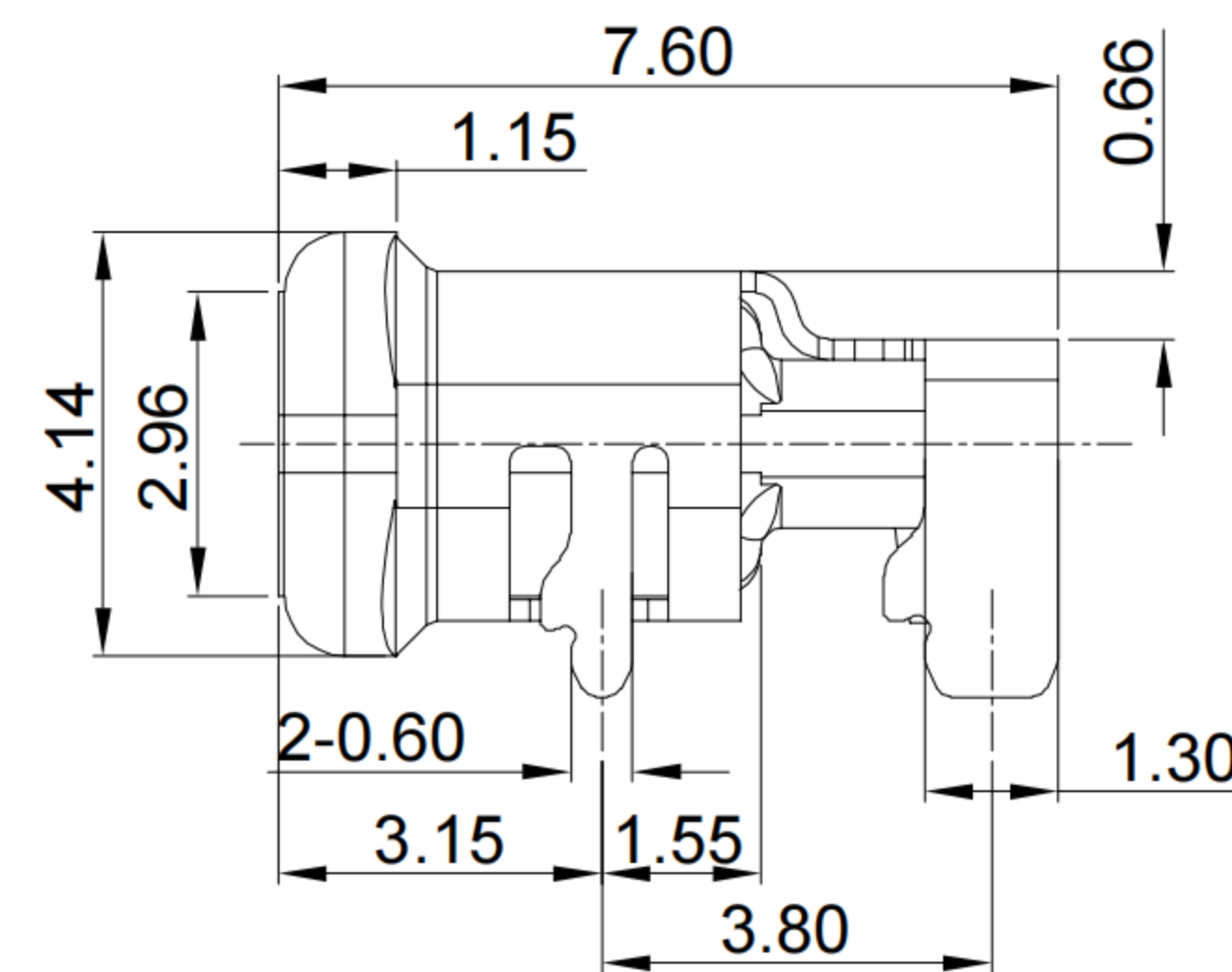
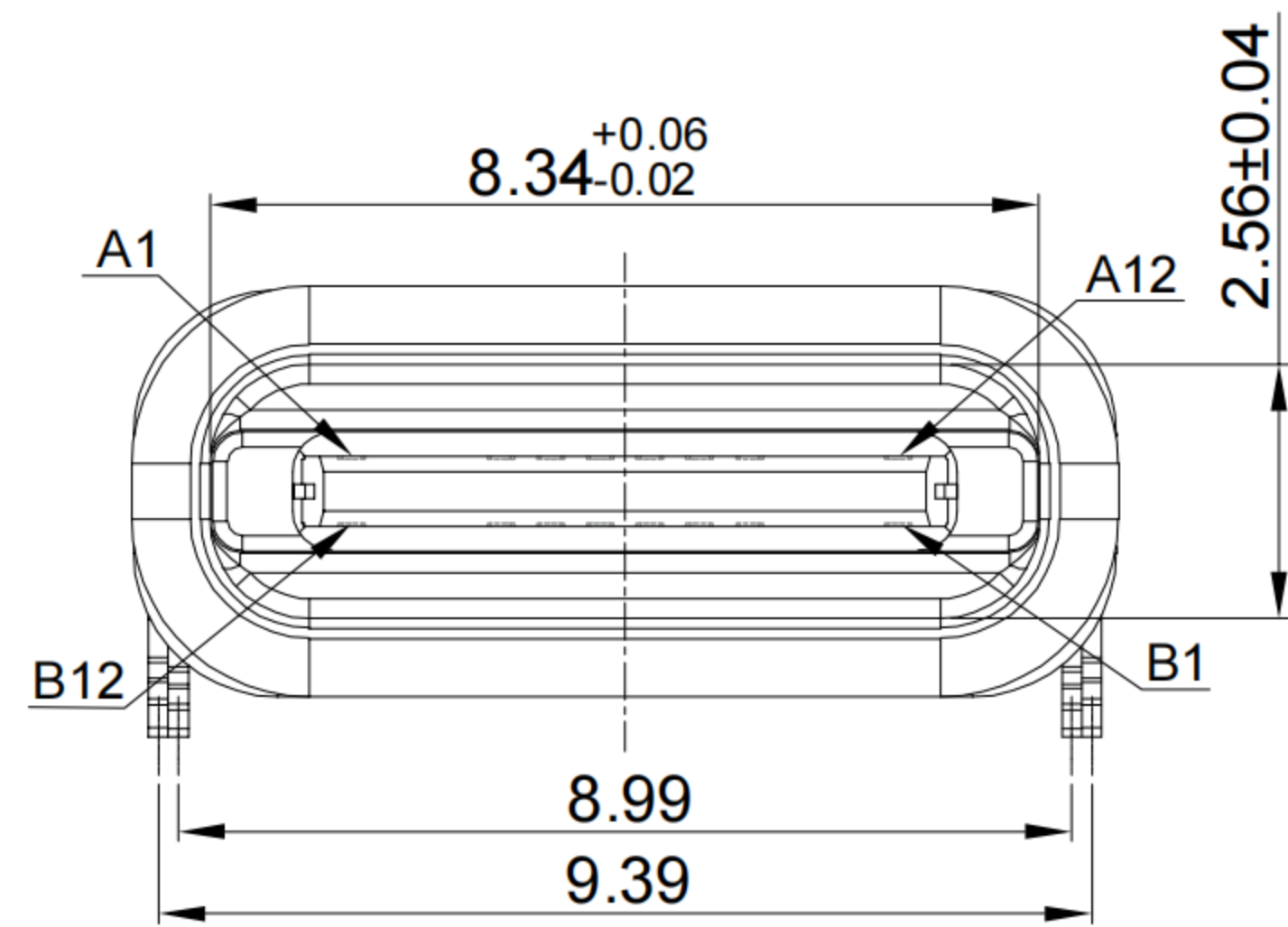

3

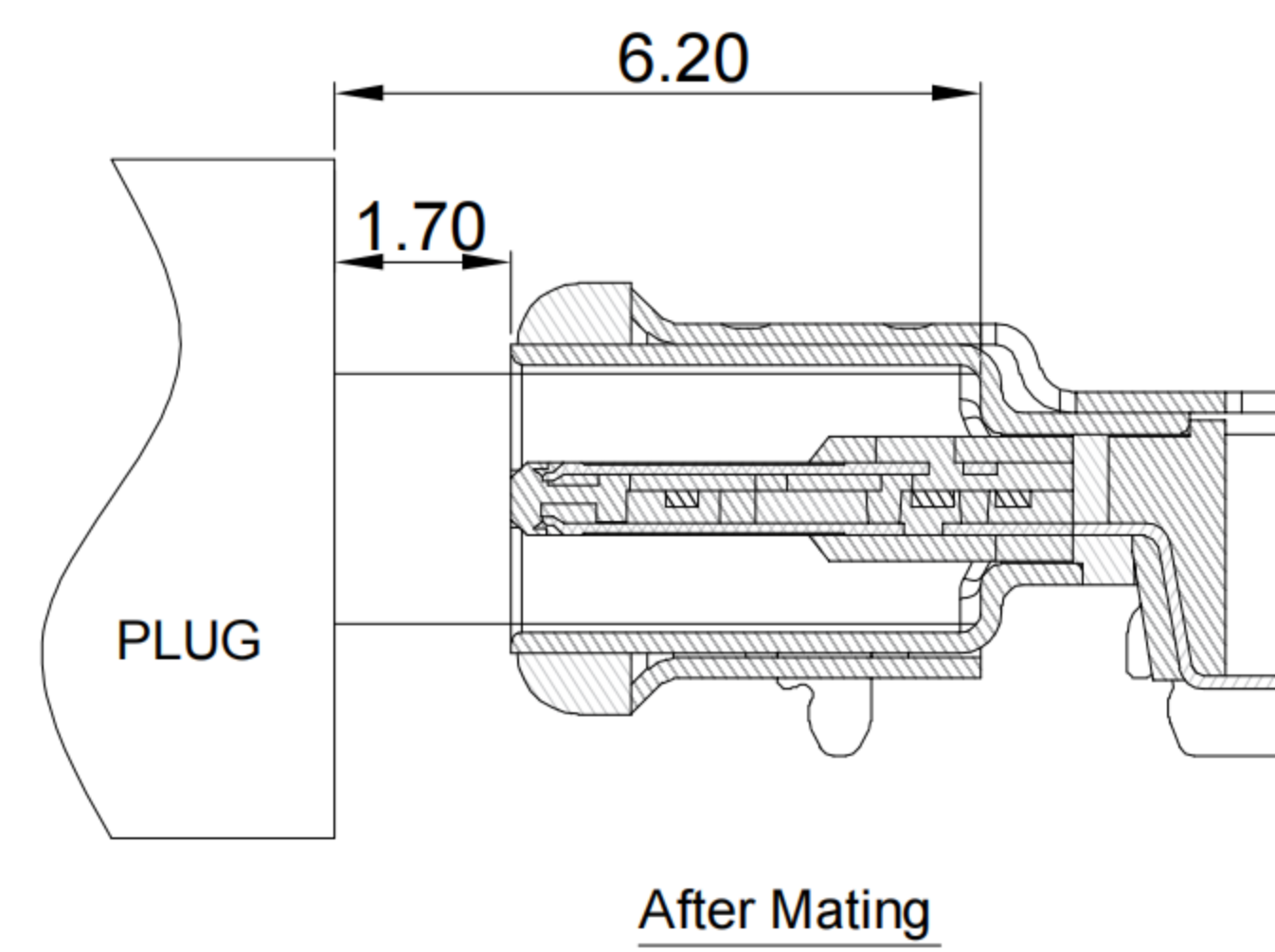
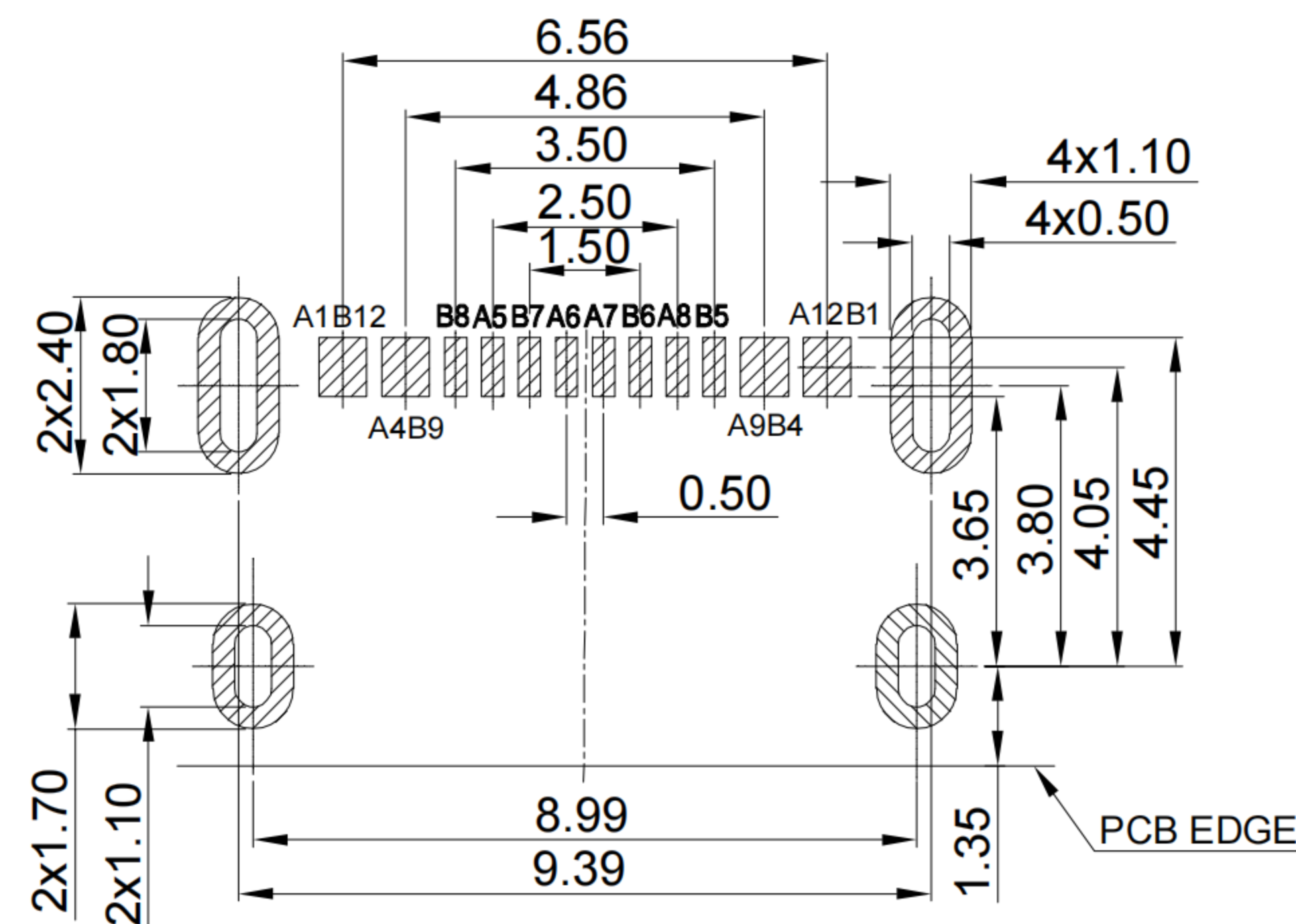
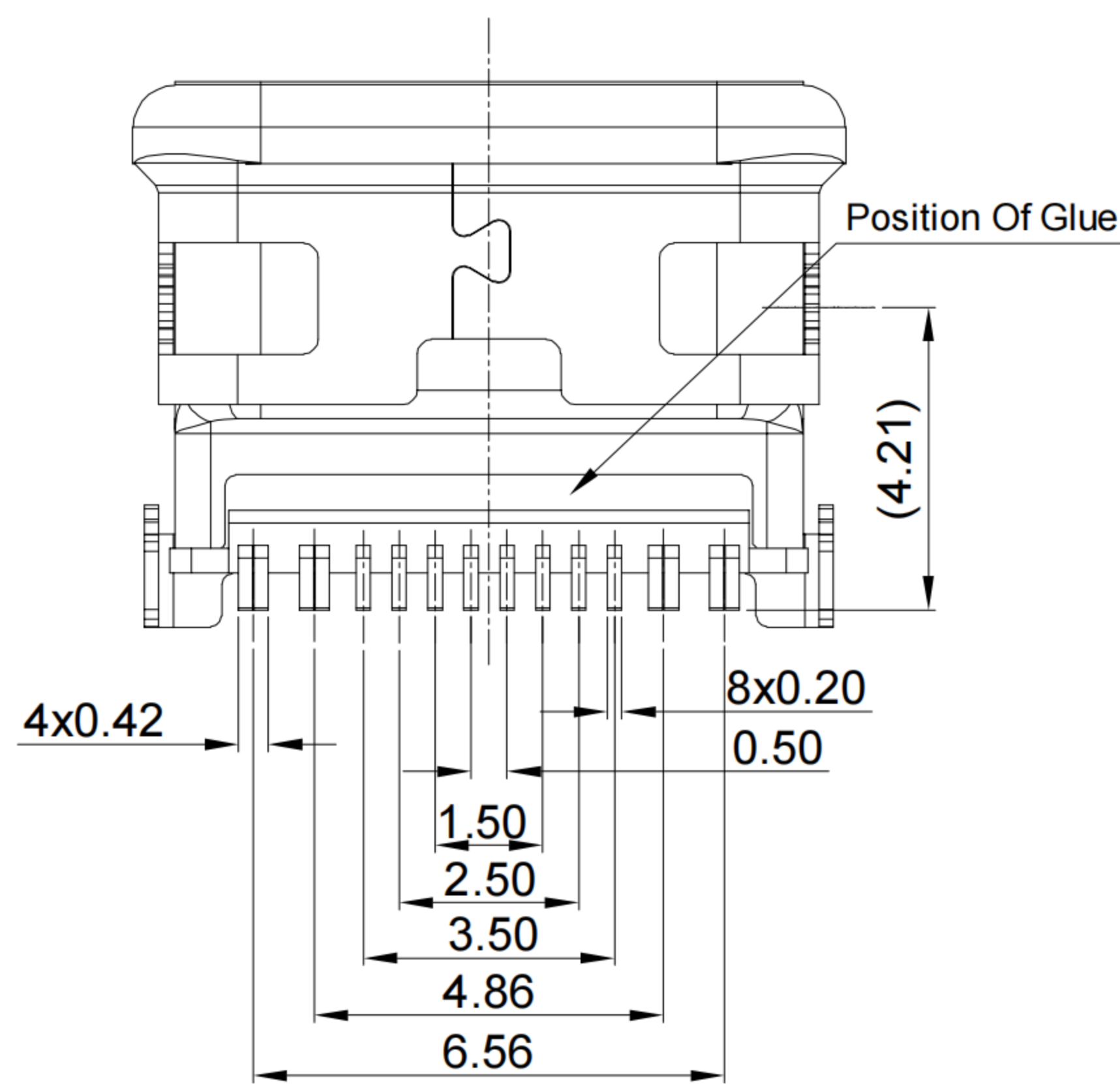

G-Switch USB-C Specification:

1. Current rated: 5A on vbus/1.25A on vconn/0.25A on other
2. Voltage rating: 24V AC
3. Withstanding voltage: 100V AC/minute
4. Contact resistance: 40mΩ Max
5. Insulation resistance: 100MΩ Min
6. Operating temperature: -40°C ~ +85°C
7. Mating force : 5N~20N
8. Unmating force: 8N~20N
9. Durability cycle: 10,000 cycles
9. Waterproof grade: IP-X7

A1	A2	A3	A4	A5	A6	A7	A8	A9	A10	A11	A12
GND			VBUS	CC1	D+	D-	SBU1	VBUS			GND
First			First	Second	Second	Second	Second	First			First
B12	B11	B10	B9	B8	B7	B6	B5	B4	B3	B2	B1
GND			VBUS	SBU2	D-	D+	CC2	VBUS			GND
First			First	Second	Second	Second	Second	First			First

5

1	SHELL	STAINLESS STEEL	NI PLATED
2	SHELL	STAINLESS STEEL	NI PLATED
3	MID PLATE	STAINLESS STEEL	--
4	HOUSING	HIGH TEMPERATURE PLASTIC	BLACK UL 94 V-0
5	TERMINALS	COPPER ALLOY	Au Plating On Contact Area Ni and Matte Tin On Solder Area
6	GLUE	EPOXY	BLACK
7	OUT GASKET	UV GLUE	RED
NO.	PARTS	MATERIAL	REMARKS

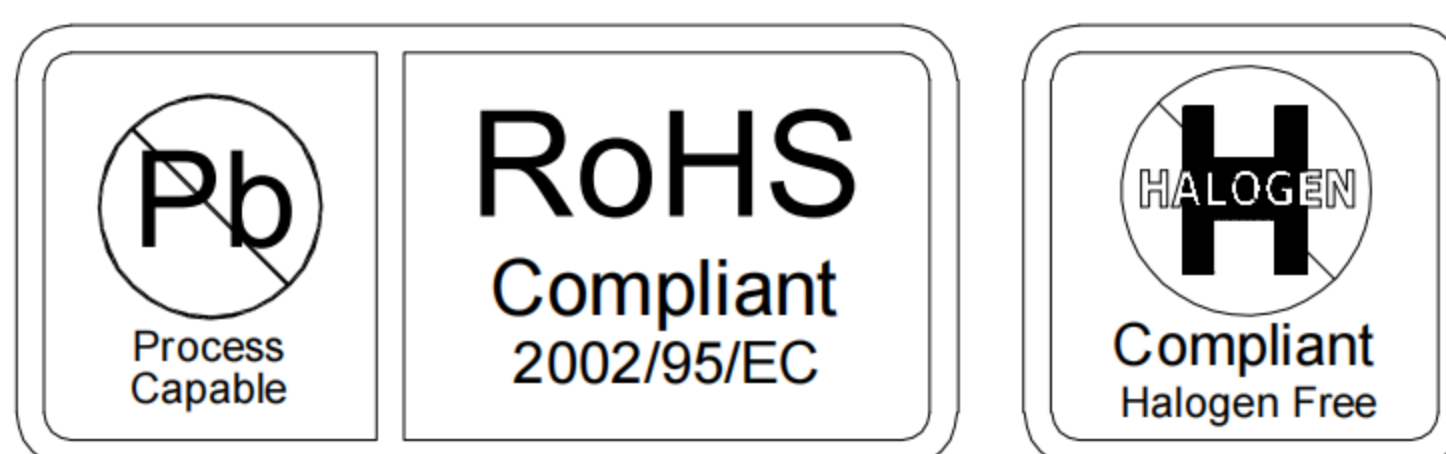
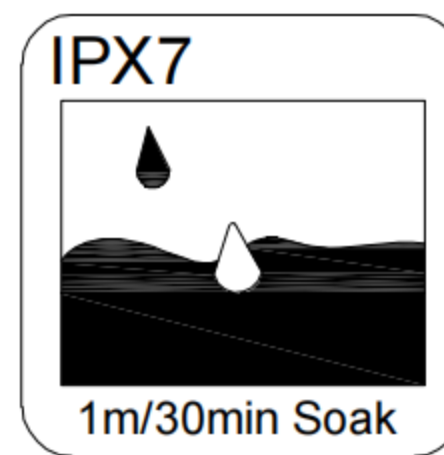

SCALE: 4:1 UNIT: mm
 SIZE: A4

Unless otherwise
 General Tolerance:
 X. ±0.20
 X.x ±0.15
 X.xx ±0.10
 X.xxx ±0.05
 Angles ±3°

Title: Horizontal Type-c 16P Female
 SMT CH=1.82 L=7.6mm

Molde Code: GT-USB-7098A

DRAWN	CHECKED	APPROVED	DATE
Xia	Chen	Chen	2022.11.01



REV: A0 SHEET:

A

B

C

D

E